

CONSTRUCTION	ROTATION	DISCH PORT
VERTICAL TOP	CLOCKWISE (CW)	RIGHT SIDE
	COUNTERCLOCKWISE (CCW)	LEFT SIDE
VERTICAL BOTTOM	CLOCKWISE (CW)	LEFT SIDE
	COUNTERCLOCKWISE (CCW)	RIGHT SIDE

ESTIMATED WEIGHT - 1100 LBS

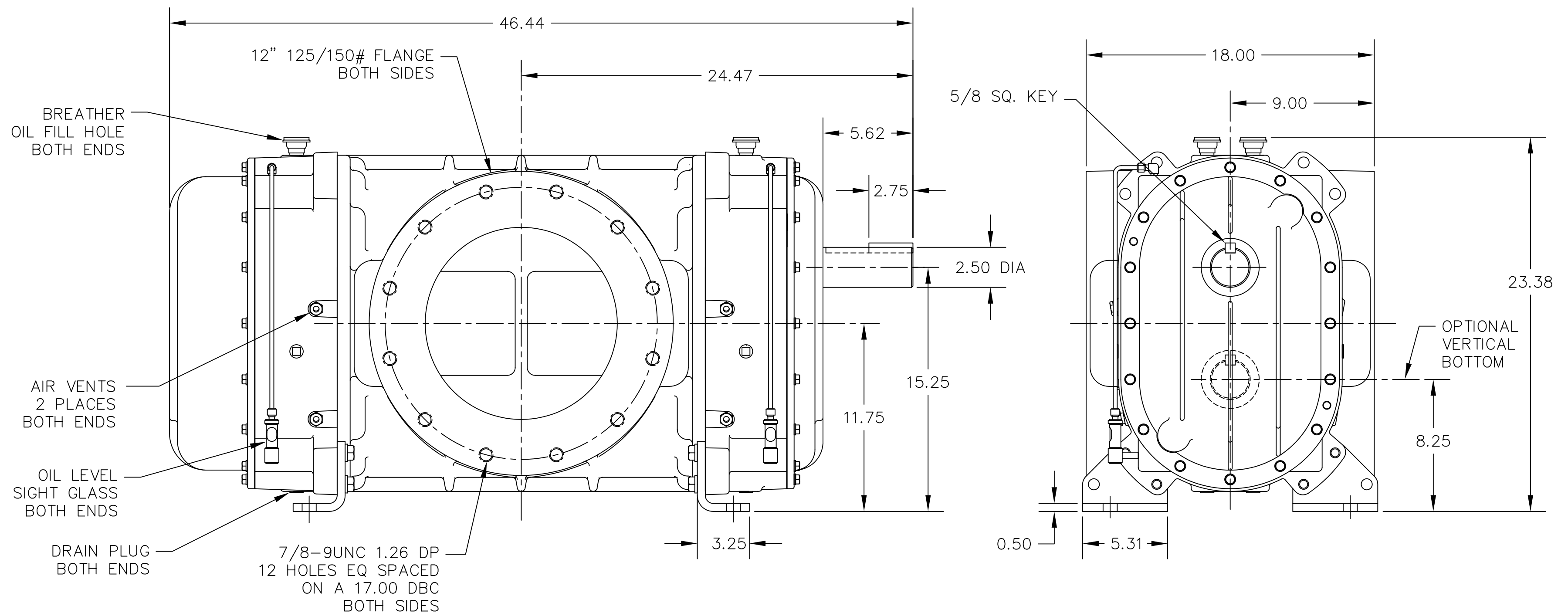

C. Emery Nelson, Inc.
INDUSTRIAL AND POWER PLANT EQUIPMENT
7631 Commerce Street, Hamel, MN 55340
Ph: 763/420-3844 Fax: 763/420-2542

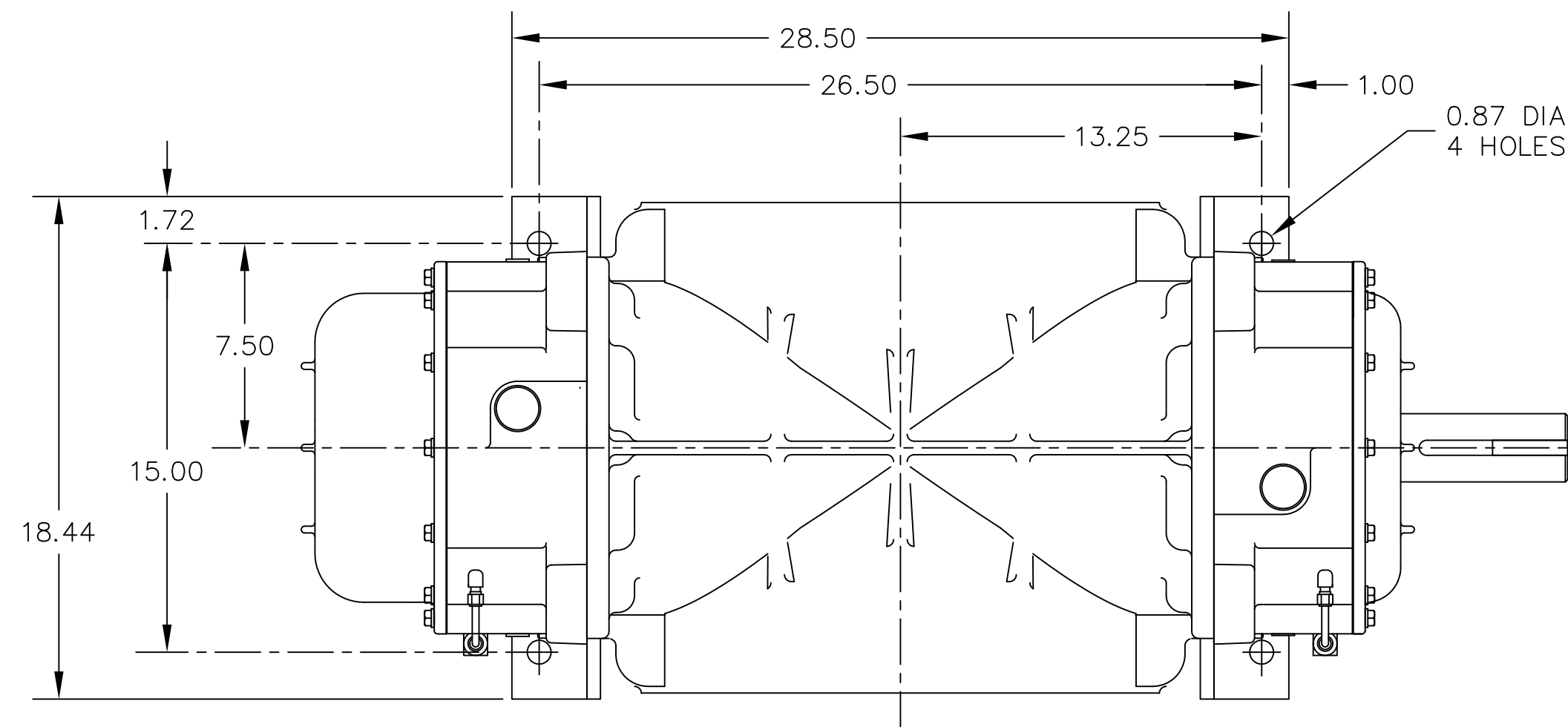

CONFIDENTIAL - THE INFORMATION CONTAINED IN THIS DOCUMENT IS THE PROPERTY OF GARDNER DENVER MACHINERY INC. IT IS NOT FOR PUBLIC DISCLOSURE. POSSESSION OF THE INFORMATION DOES NOT CONVEY ANY RIGHT TO LOAN, SELL OR DISCLOSE THE INFORMATION. UNAUTHORIZED REPRODUCTION OR USE OF THE INFORMATION IS PROHIBITED. THIS DOCUMENT IS TO BE RETURNED TO GARDNER DENVER MACHINERY INC. UPON COMPLETION OF THE PURPOSE FOR WHICH IT IS LOANED OR UPON REQUEST.

TAP DRILL DEPTHS ARE MAXIMUM. FULL THD. DEPTHS ARE MINIMUM.

FINISH OF CHAMFERS & FILLETS TO CONFORM TO ROUGHEST ADJACENT AREA

SURFACE ROUGHNESS MAX. PER ASA SPEC.

LET.	REVISION	DATE	DR.	CK.	LET.	REVISION	DATE	DR.	CK.	LET.	REVISION	DATE	DR.	CK.
A	RELEASED (C/M 1028500)													



Gardner Denver Inc.
Peachtree City, Georgia

TOLERANCES: UNLESS OTHERWISE SPECIFIED
DECIMAL .XX ± .02 .XXX ± .010
NON-DECIMAL ± 1/16 ANGLES ± 1°

HEAT TREAT SPEC. -

SHEET 1 OF 1

FOR ALL CURRENT SPECIFICATIONS REFER TO BILL OF MATERIAL

NAME: OUTLINE-BARE UNIT
7023 DUROFLOW VERTICAL

DR.	SLM	11/22/05	MET. APP.
CK.	SM	11/22/05	ENG. APP.

SCALE: 3/16

309GGG800

FILE NO. C CAD/CAM