

ZONE		REV	DESCRIPTION	DATE	DWN	CHK
A			RELEASED PER ECR 10/02/11			
B			REVISED AND REDRAWN PER ECR 10/01/16	09/14/2012	LAT	TAM

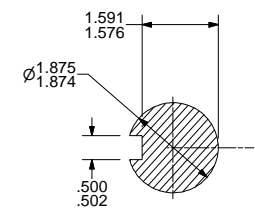

7631 Commerce Street, Hamel, MN 55340  
 Ph: 763/ 420-3844 Fax: 763/420-2542

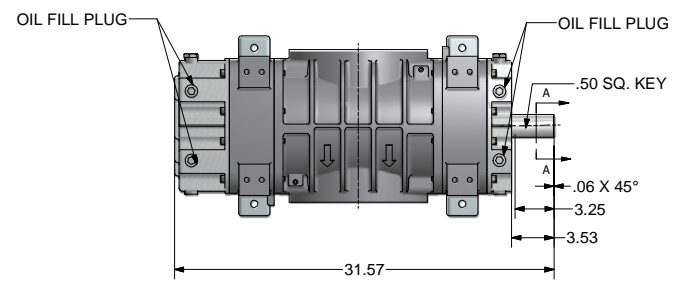

SECTION A-A  
SCALE 1 : 1

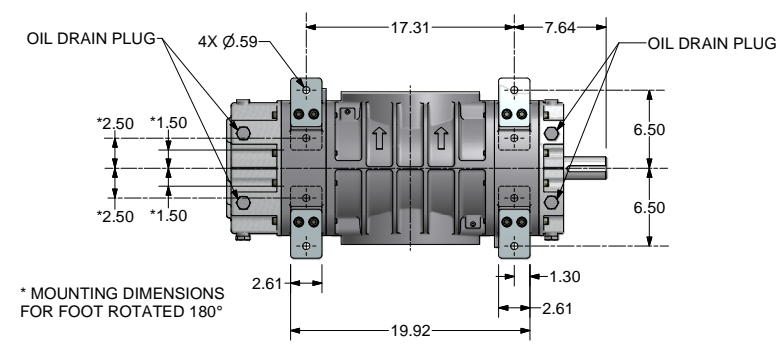
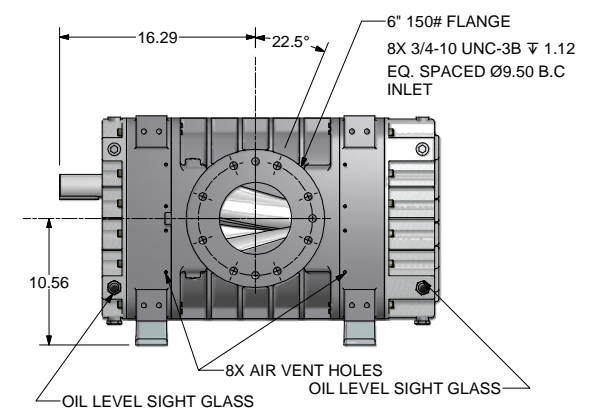
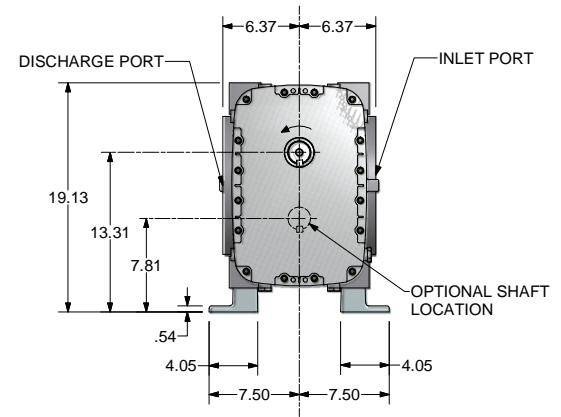
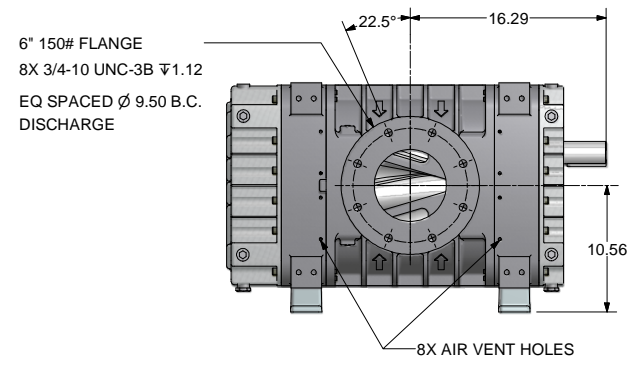

\* MOUNTING DIMENSIONS FOR FOOT ROTATED 180°

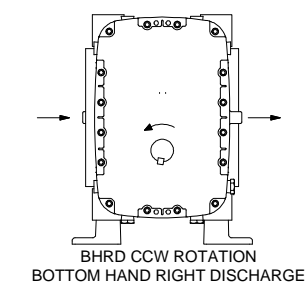
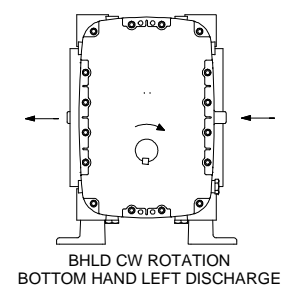
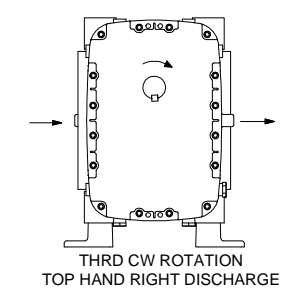
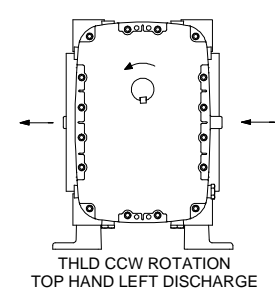

FINISH OF CHAMFERS AND FILLETS TO CONFORM TO ROUGHEST ADJACENT AREA. SURFACE ROUGHNESS MAXIMUM PER ASME B46.1. FULL THREADS THERE ARE MINIMUM.		CONFIDENTIAL - THE INFORMATION CONTAINED IN THIS DOCUMENT IS THE PROPERTY OF GARDNER DENVER, INC. IT IS NOT FOR PUBLIC DISCLOSURE. POSSESSION OF THE INFORMATION DOES NOT CONVEY ANY RIGHT TO LEASE, SELL OR DISCLOSE THE INFORMATION. UNAUTHORIZED REPRODUCTION OR USE OF THE INFORMATION IS PROHIBITED. THIS DOCUMENT IS TO BE RETURNED TO GARDNER DENVER, INC. UPON THE COMPLETION OF THE PURPOSE FOR WHICH IT IS LOANED OR UPON REQUEST.	
UNLESS OTHERWISE SPECIFIED DIMENSIONS ARE IN INCHES		DIMENSIONING AND TOLERANCING PER ASME Y14.5-2009	
TOL. ON DECIMALS: X = ± .05		THREADS PER INCH: B1.1 (GAGING SYSTEM) 2.1 U.O.S., AND B1.20.1 & B1.20.3	
TOL. ON DECIMALS: XX = ± .02		Gardner Denver Inc. HEAT TREATMENT	
TOL. ON DECIMALS: XXX = ± AS SPECIFIED		Quincy, IL ENG. REF:	
TOL. ON ANGLES: ± 0°-30'		OUTLINE-BARE UNIT	
THIRD ANGLE PROJECTION		HELIFLOW 514 VERTICAL	
DWN BY: 6618 10/7/2011		303HYE800	
C/D BY: RRB 10/8/2011		1 of 1	