

REVISION HISTORY						
ZONE	REV	DESCRIPTION	ECN #	DATE	DWN	CHK
	03	CHANGED SIGHT GLASS LOCATION TO RIGHT SIDE	1121287	10-Oct-18	exs7247	mws0121

**C. Emery Nelson, Inc.**  
INDUSTRIAL AND POWER PLANT EQUIPMENT  
7631 Commerce Street, Hamel, MN 55340  
Ph: 763/420-3844 Fax: 763/420-2542

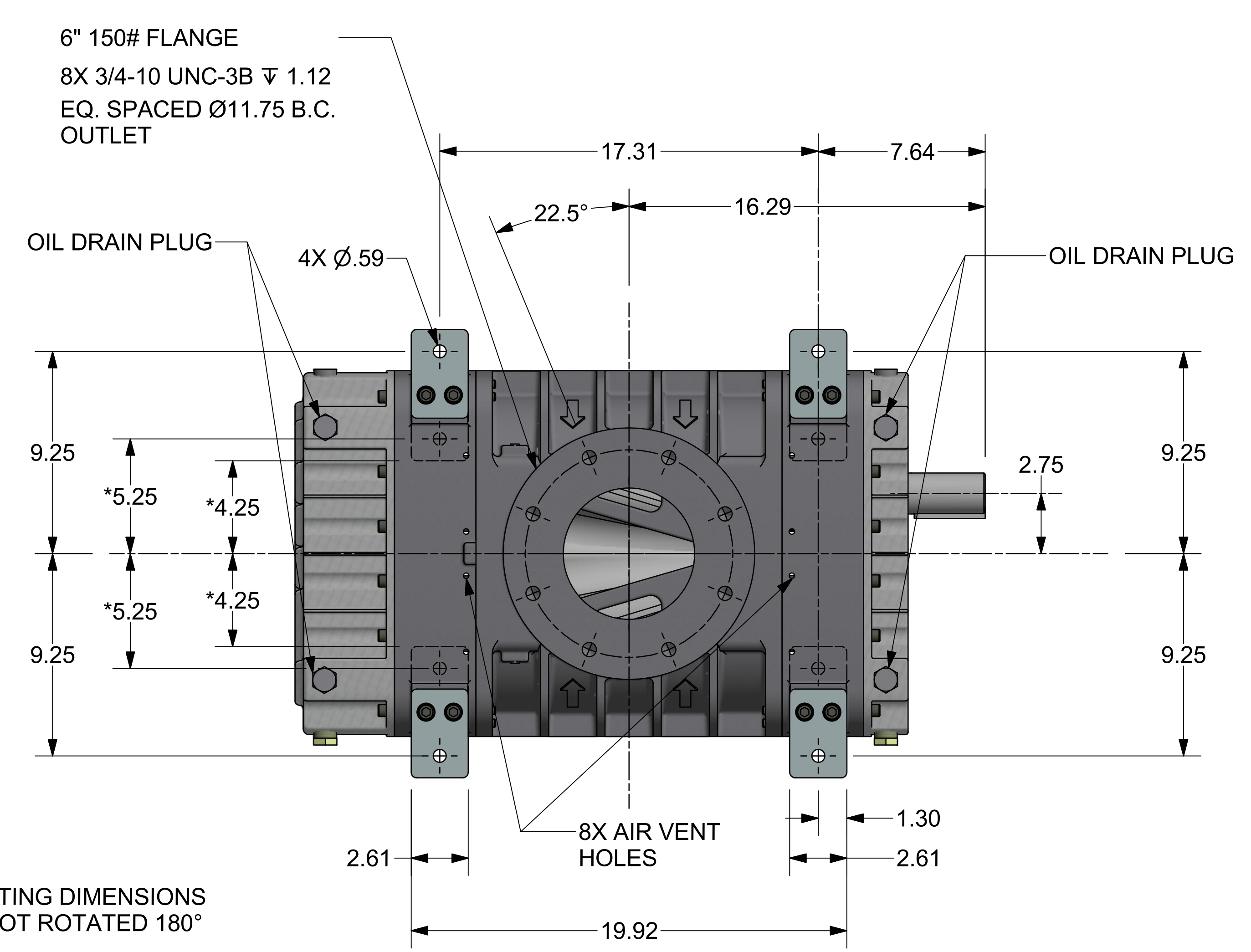

\* MOUNTING DIMENSIONS FOR FOOT ROTATED 180°

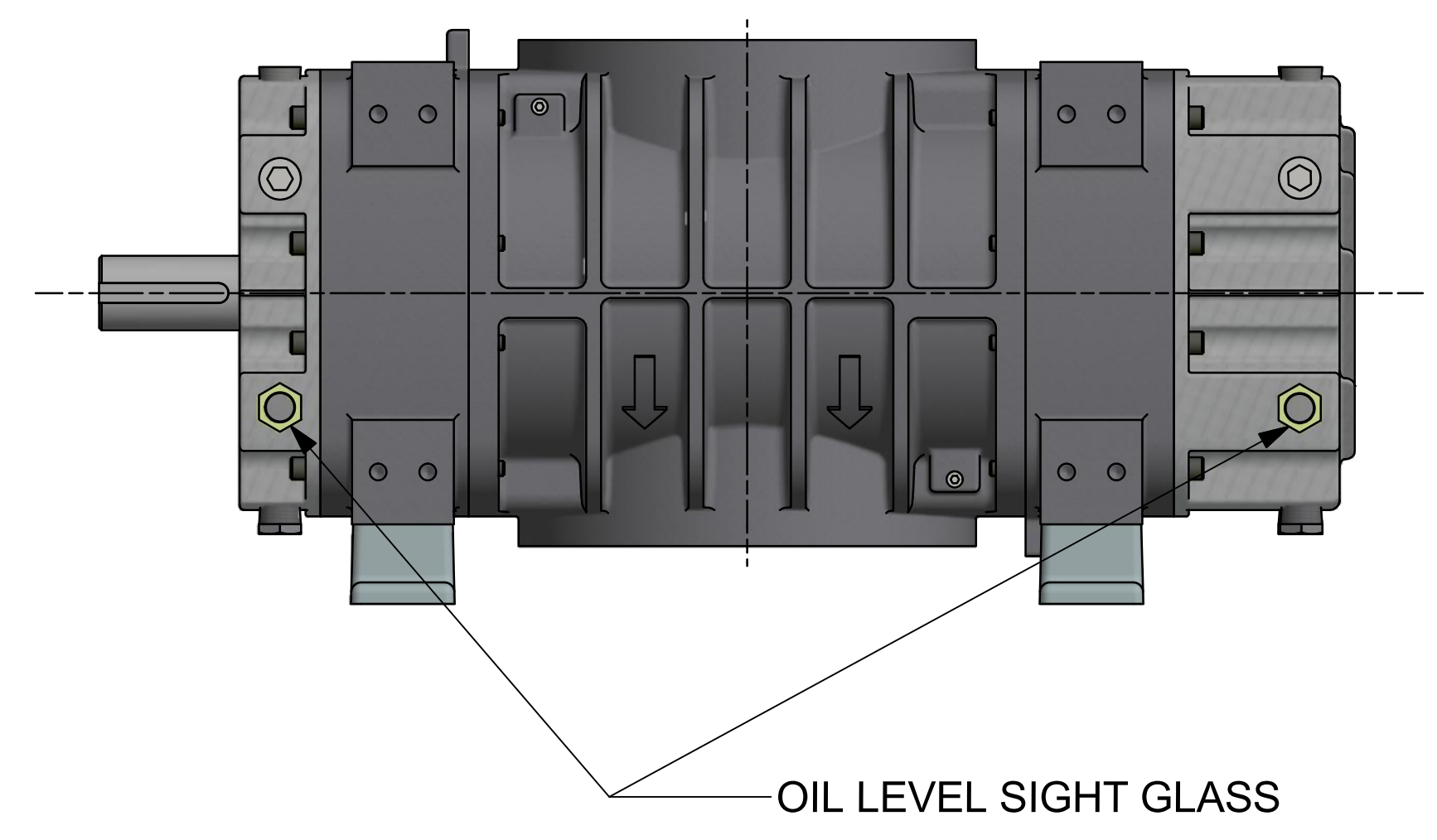
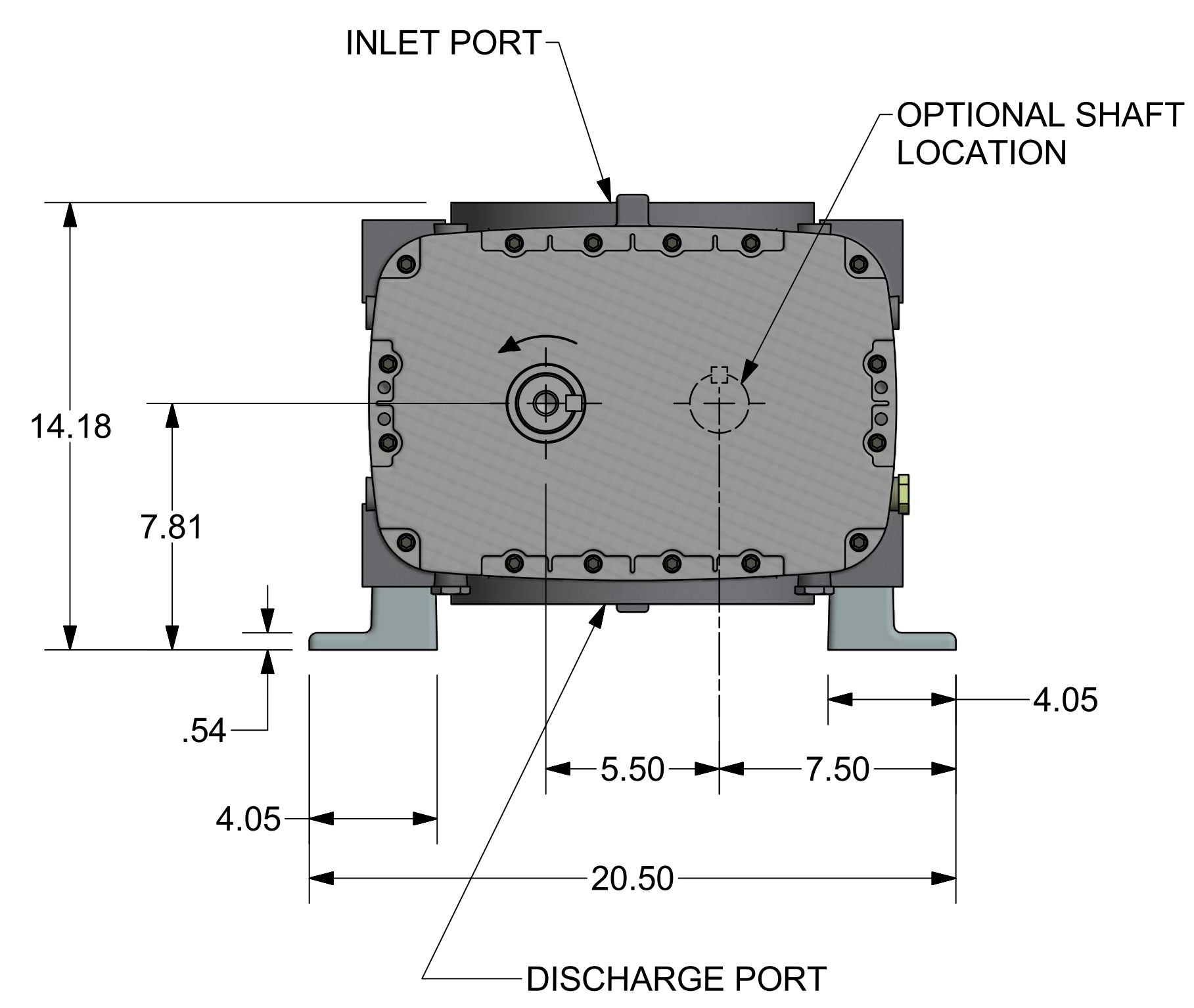
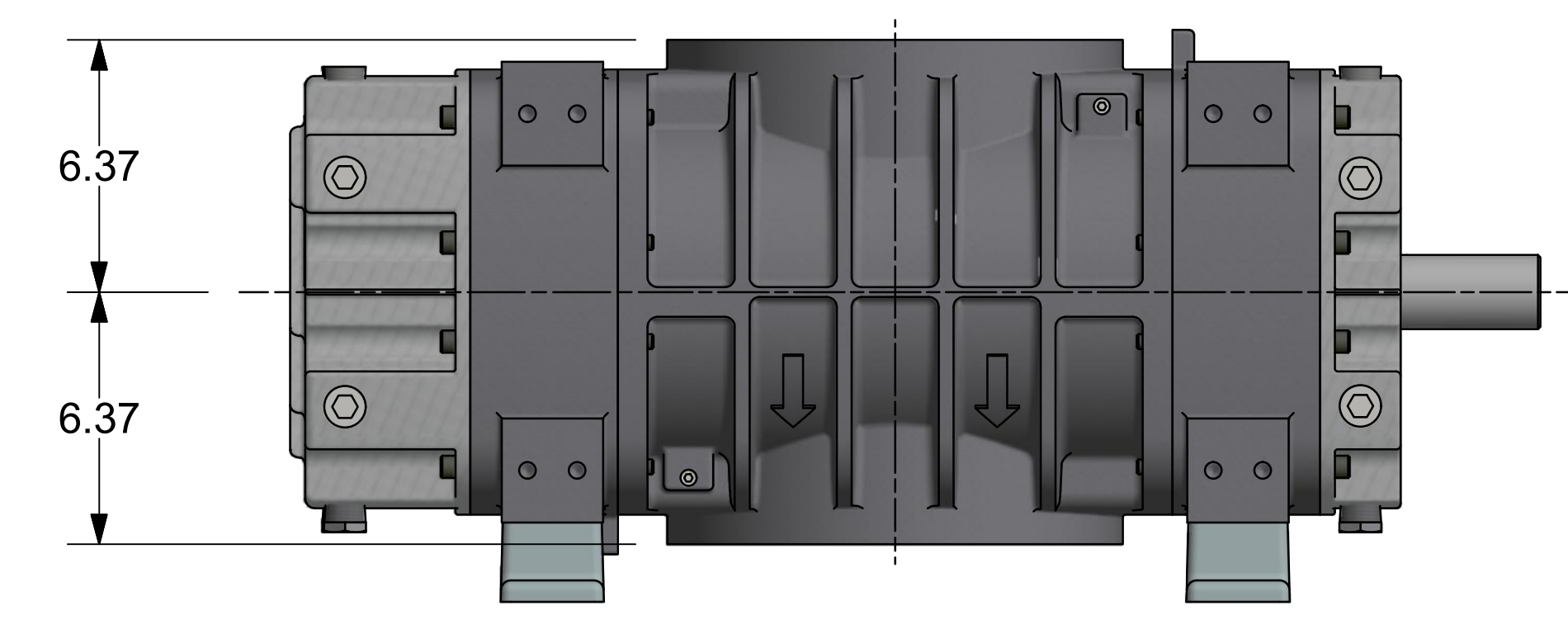
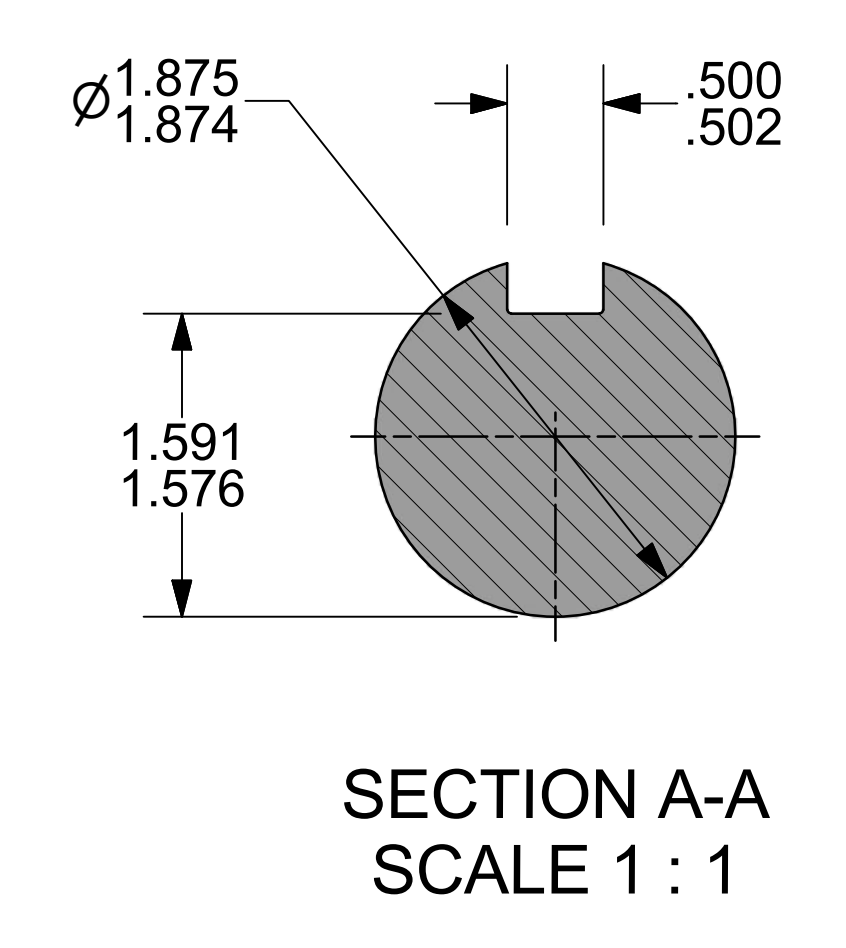
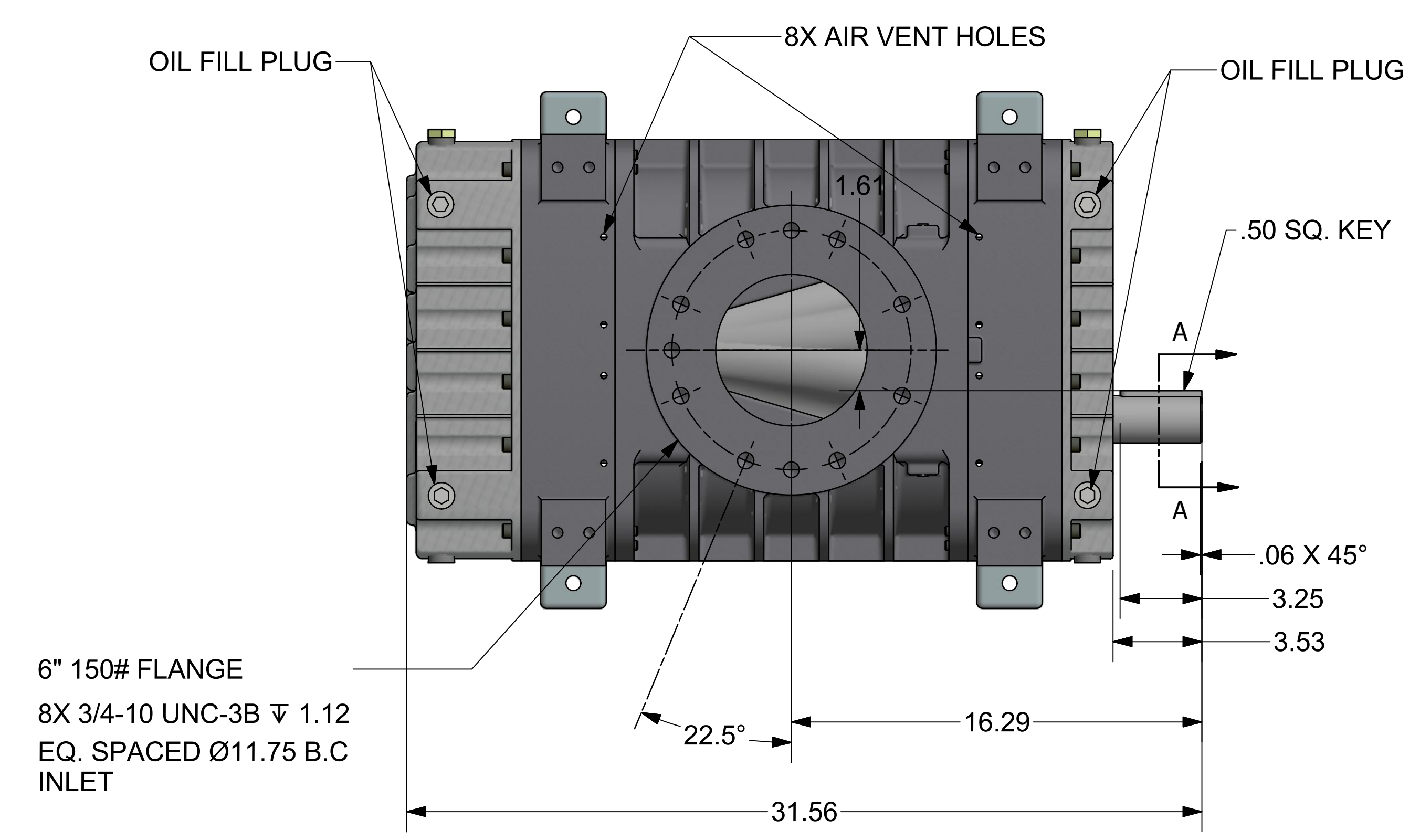
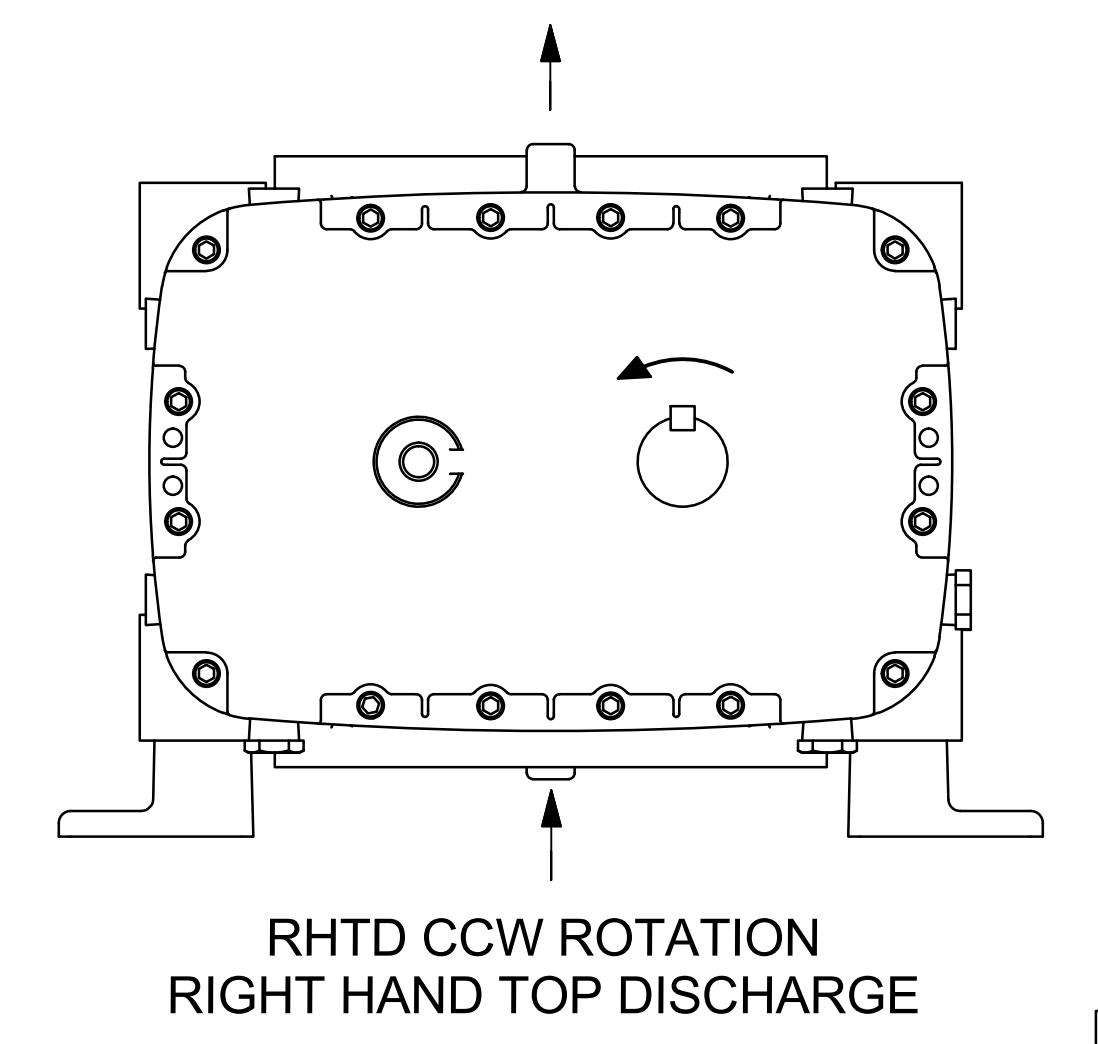
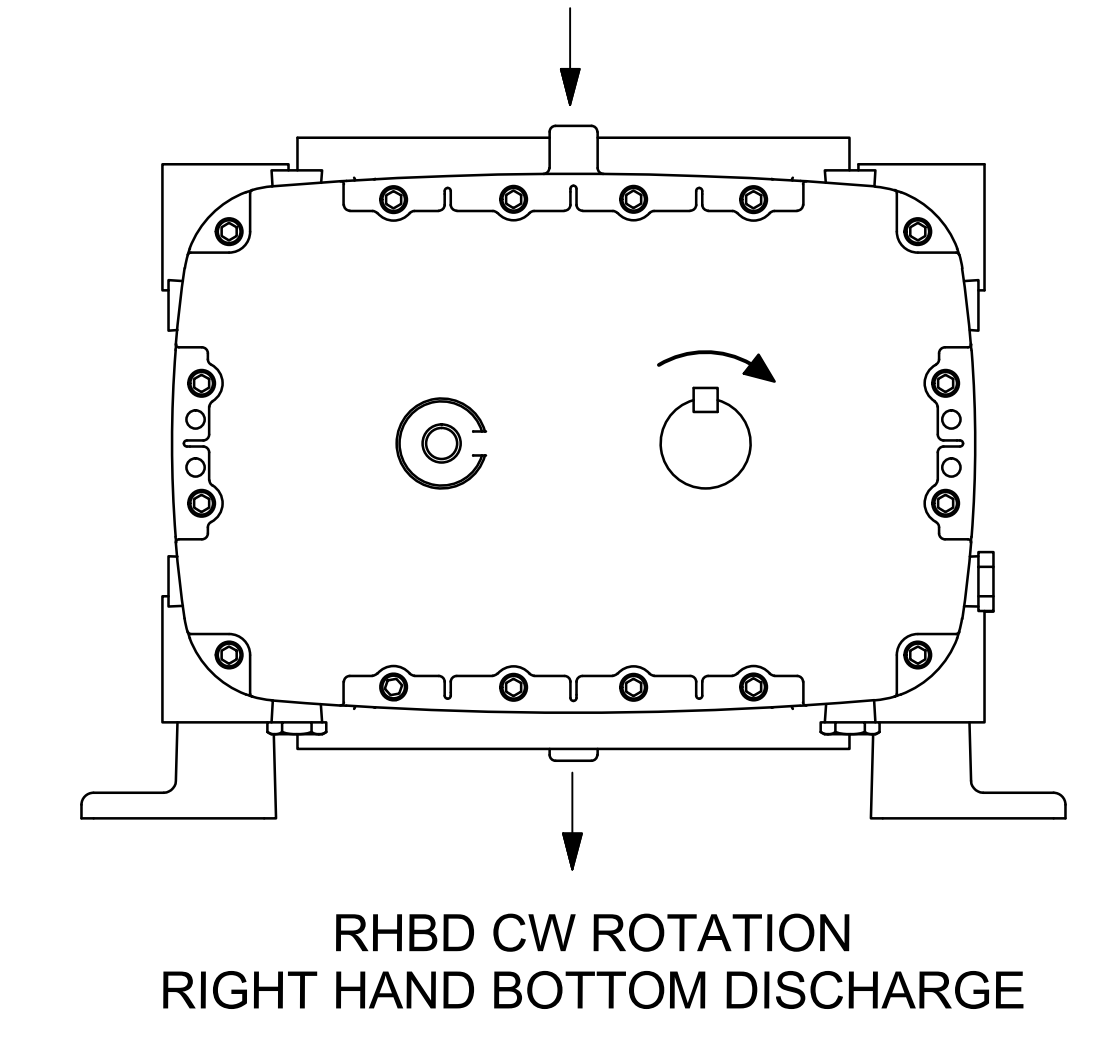
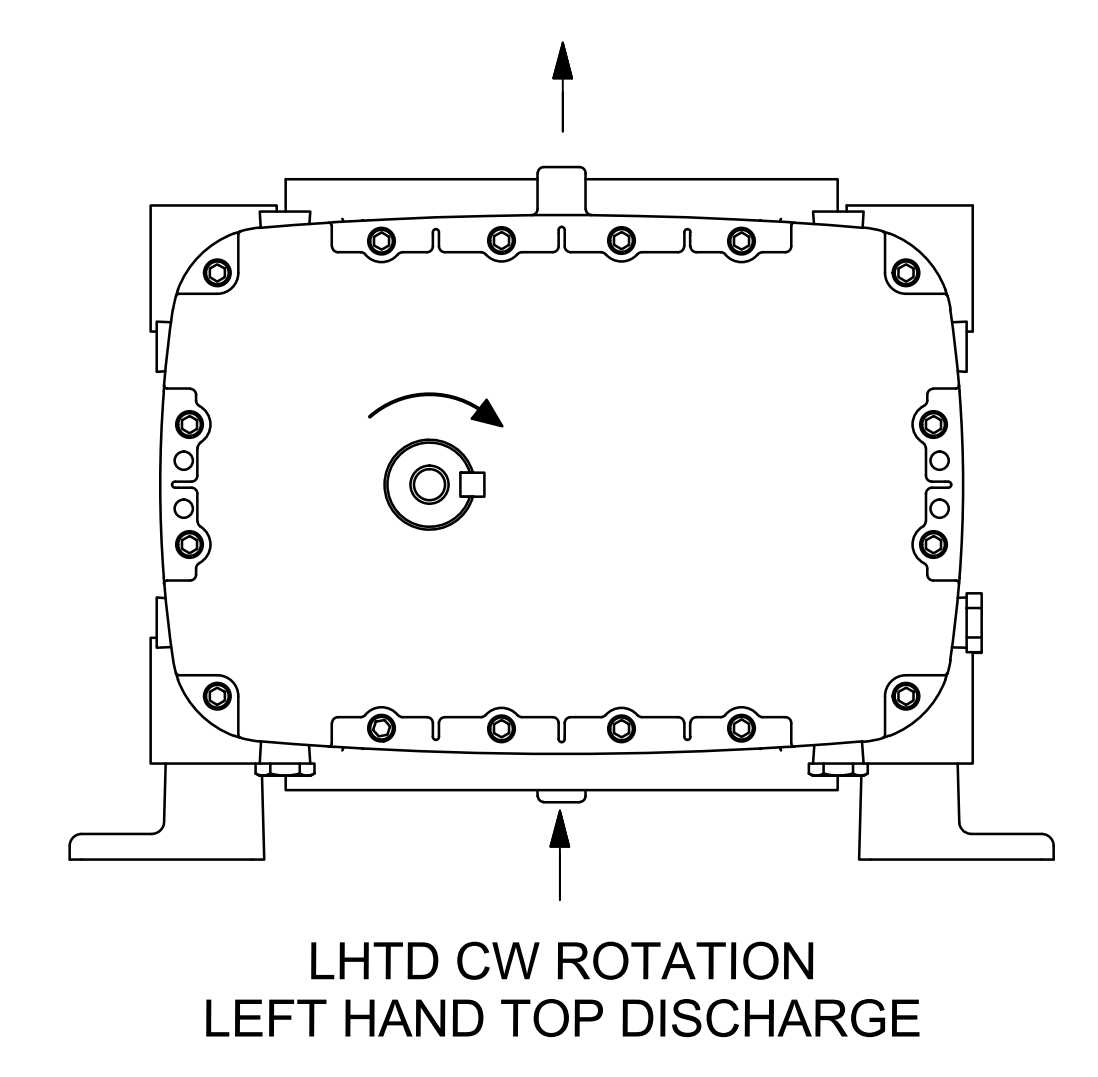
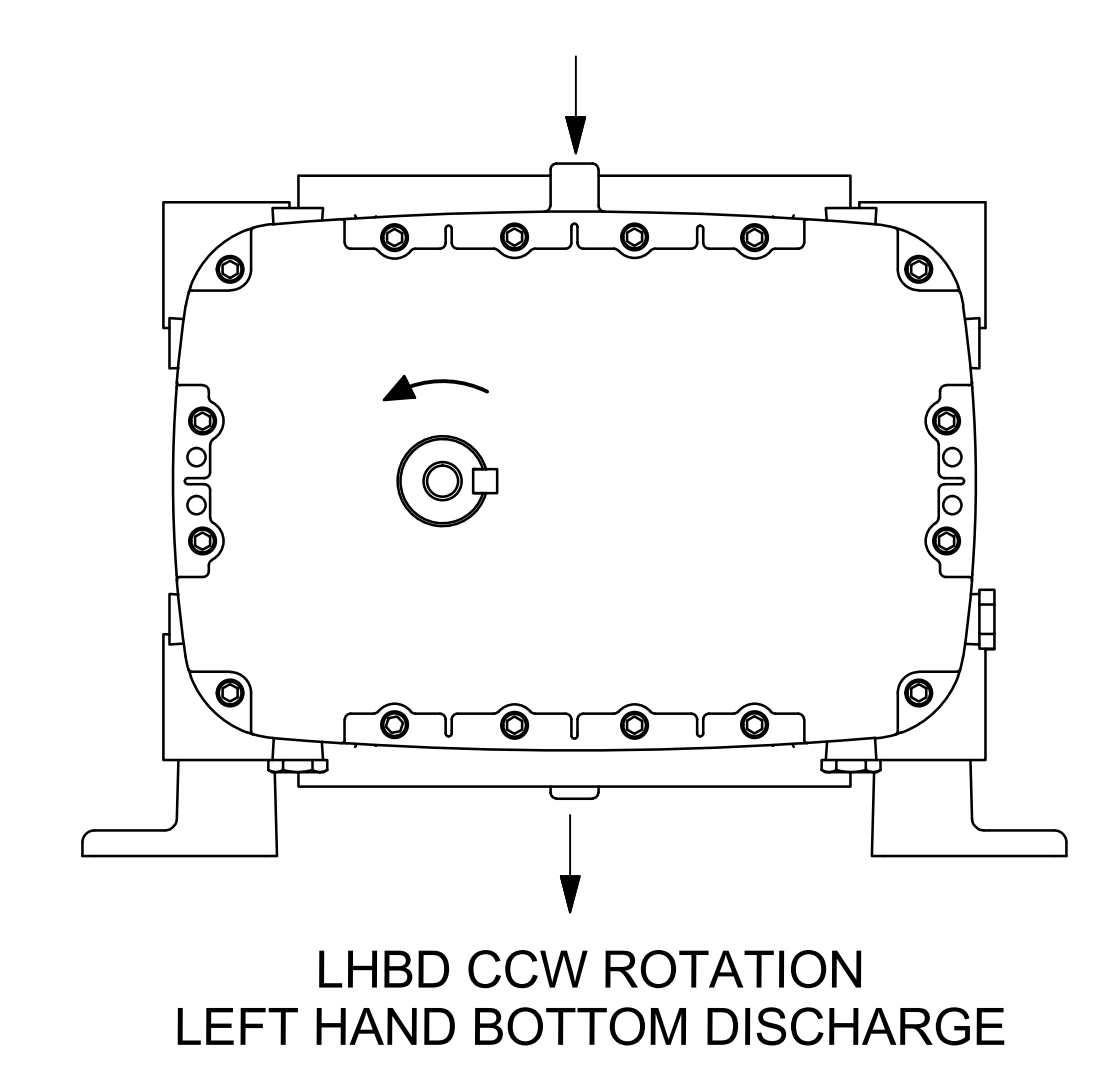

FINISH OF CHAMFERS AND FILLETS TO CONFORM TO ROUGHEST ADJACENT AREA. SURFACE ROUGHNESS MAXIMUM PER ASME B46.1. FULL THREAD DEPTHS ARE MINIMUM.

UNLESS OTHERWISE SPECIFIED DIMENSIONS ARE IN INCHES  
TOL. ON DECIMALS: X =  $\pm$  .05  
TOL. ON DECIMALS: XX =  $\pm$  .02  
TOL. ON DECIMALS: XXX =  $\pm$  AS SPECIFIED  
TOL. ON ANGLES:  $\pm$  0'-30'

THIRD ANGLE PROJECTION

CONFIDENTIAL - THE INFORMATION CONTAINED IN THIS DOCUMENT IS THE PROPERTY OF GARDNER DENVER, INC. IT IS NOT FOR PUBLIC DISCLOSURE. POSSESSION OF THE INFORMATION DOES NOT CONVEY ANY RIGHT TO LOAN, SELL, OR DISCLOSE THE INFORMATION. UNAUTHORIZED REPRODUCTION OR USE OF THE INFORMATION IS PROHIBITED. THIS DOCUMENT IS TO BE RETURNED TO GARDNER DENVER, INC. UPON THE COMPLETION OF THE PURPOSE FOR WHICH IT IS LOANED OR UPON REQUEST.

DIMENSIONING AND TOLERANCING PER ASME Y14.5-2009  
THREADS PER ASME B1.1 GAGING SYSTEM 21 U.O.S., ANSI B1.20.1 & B1.20.3

Gardner Denver Inc. Quincy, IL	HEAT TREATMENT	ENG. REF:
TITLE OUTLINE-BARE UNIT		
DWN BY TAM 09-Oct-11	SIZE E	302HYE800
CKD BY RRB 09-Oct-11	SCALE 1/4	SHEET 1 OF 1