

LET	REVISION	DATE	DR.	CK.
A	RELEASED (C/M 1023202)	11/22/04	SLM	SM

GDHF-DIM-406H
DATE-10/01/07

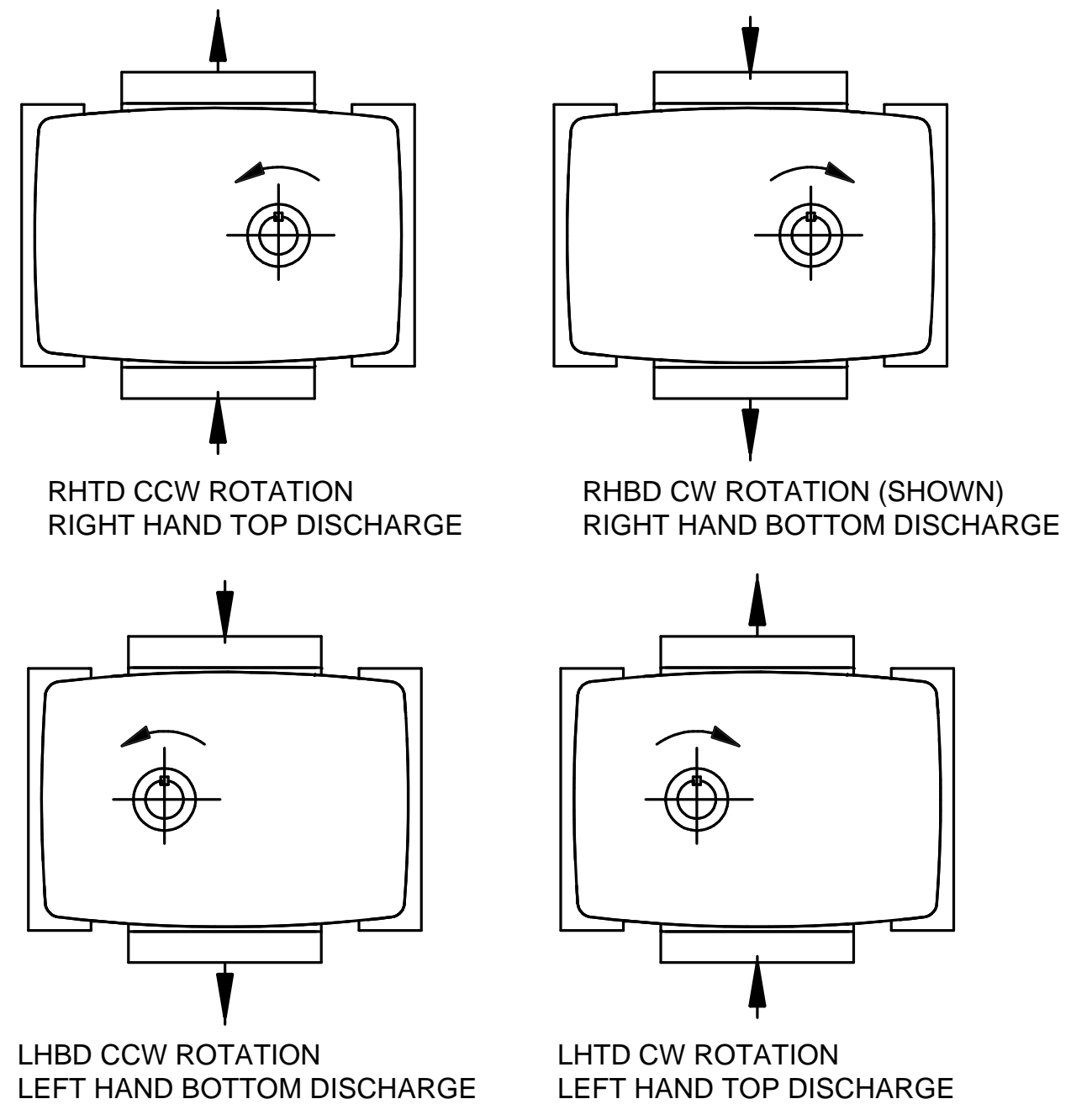
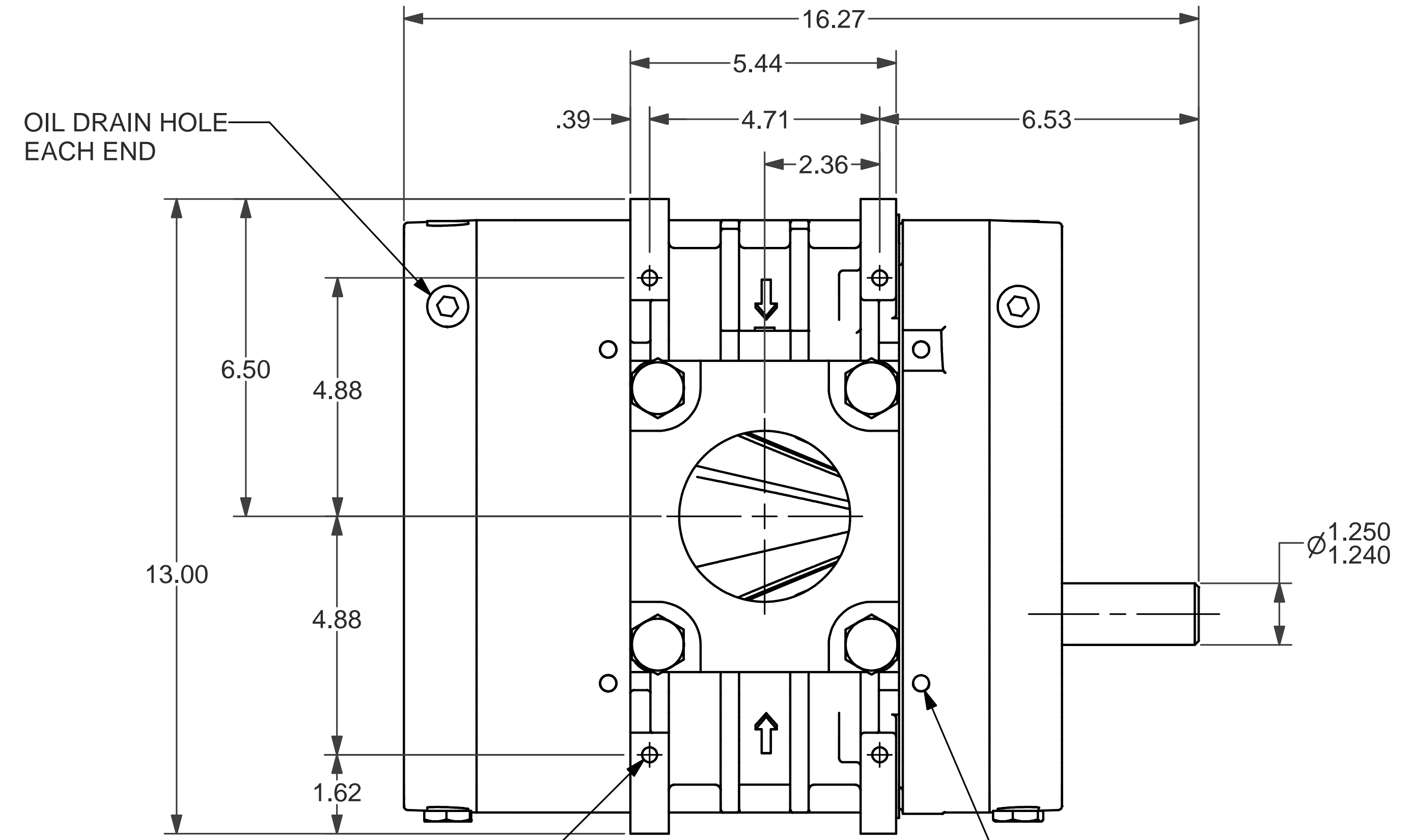
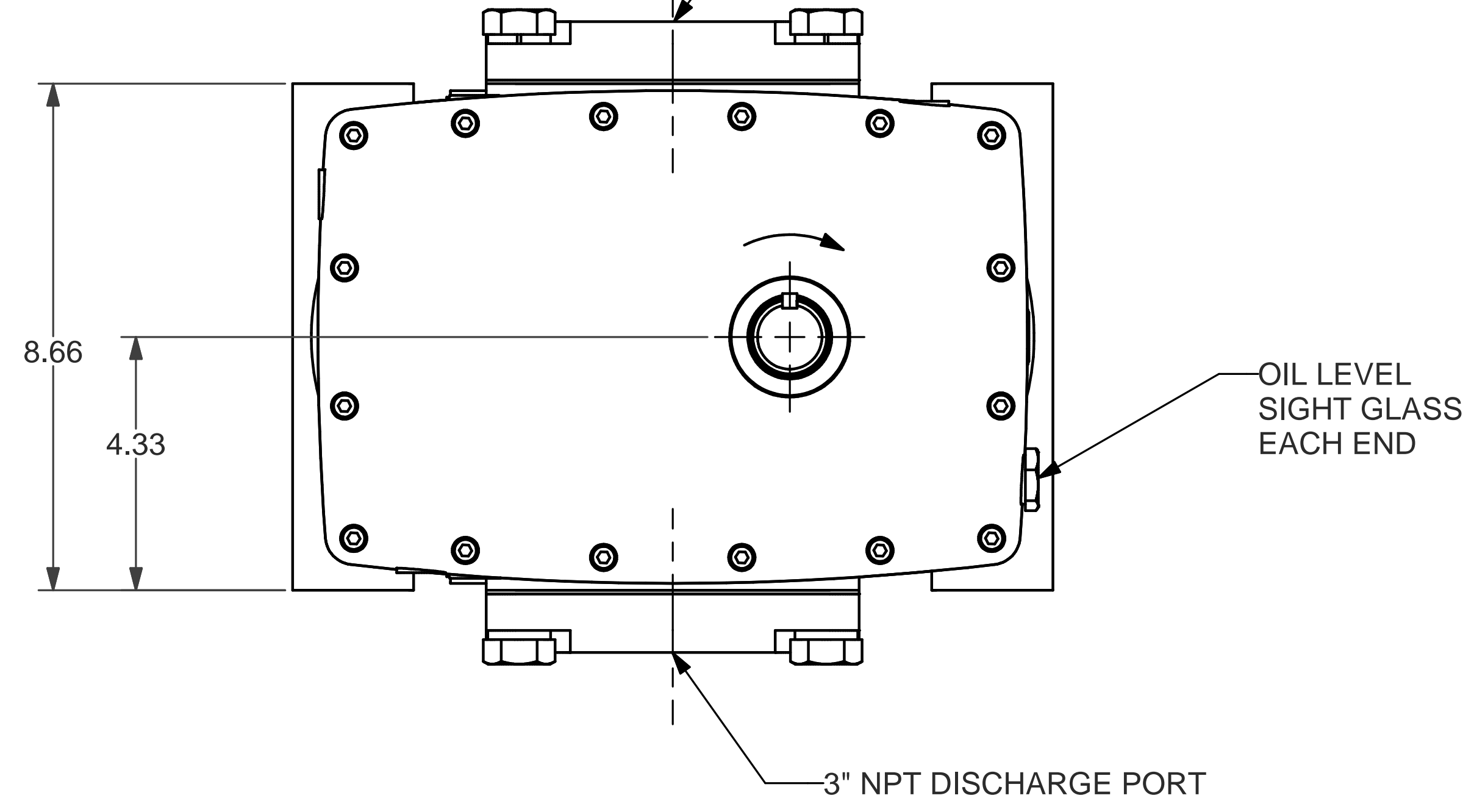
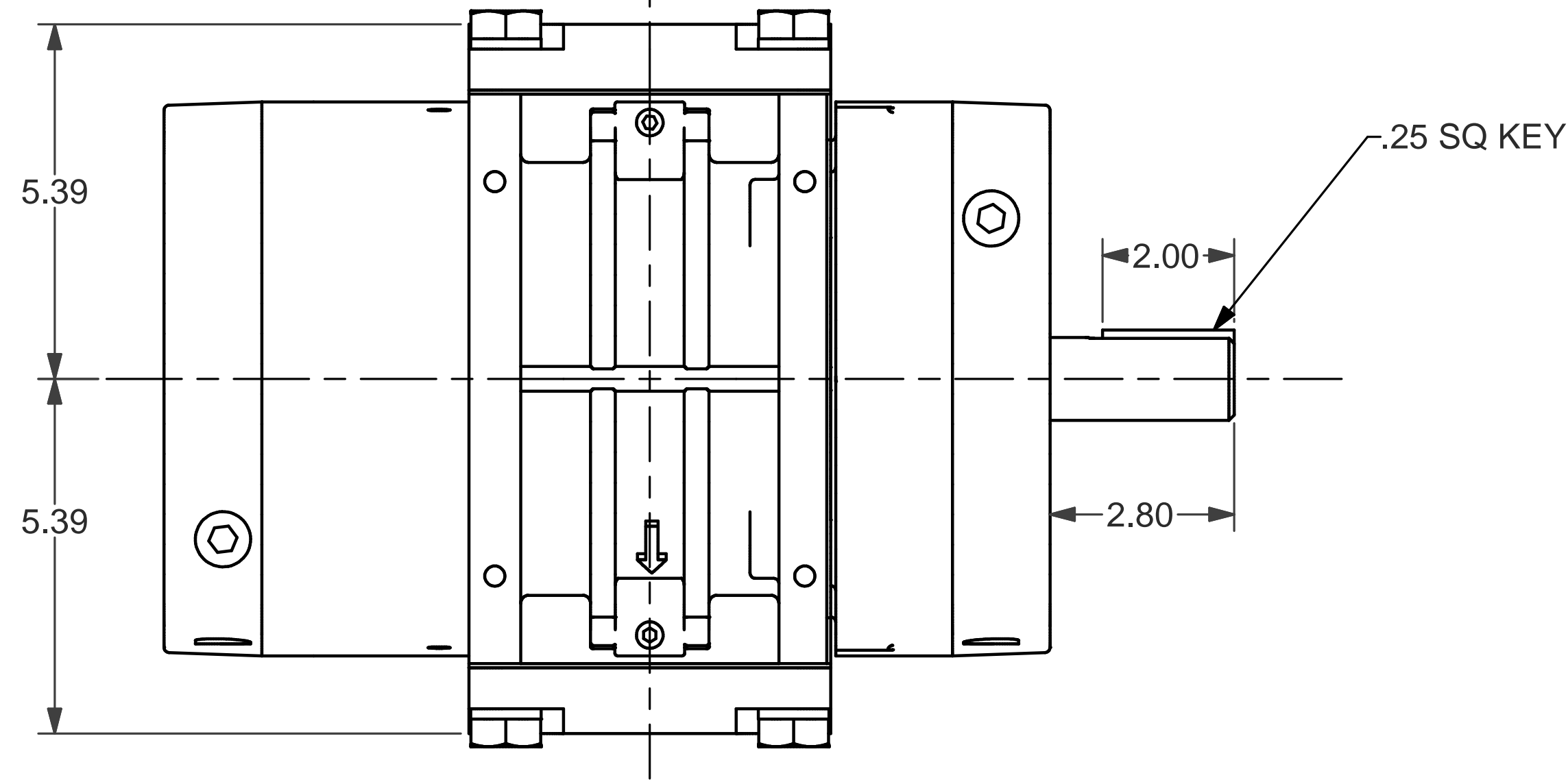

C. Emery Nelson, Inc.
INDUSTRIAL AND POWER PLANT EQUIPMENT
7631 Commerce Street, Hamel, MN 55340
Ph: 763/ 420-3844 Fax: 763/420-2542

3/8-16UNC X .68 DEEP
4 HOLES TOP & BOTTOM

FINISH OF CHAMFERS AND FILLETS TO CONFORM TO ROUGHEST ADJACENT AREA. SURFACE ROUGHNESS MAXIMUM PER ASME B46.1 SPEC. TAP DRILL DEPTHS ARE MAXIMUM. FULL THREAD DEPTHS ARE MINIMUM. UNLESS OTHERWISE SPECIFIED DIMENSIONS ARE IN INCHES TOL. ON DECIMALS: .X = ± .05 TOL. ON DECIMALS: .XX = ± .02 TOL. ON DECIMALS: .XXX = ± .010 TOL. ON ANGLES: ° 0'-30'	CONFIDENTIAL - THE INFORMATION CONTAINED IN THIS DOCUMENT IS THE PROPERTY OF GARDNER DENVER, INC. IT IS NOT FOR PUBLIC DISCLOSURE. POSSESSION OF THE INFORMATION DOES NOT CONVEY ANY RIGHT TO LOAN, SELL OR DISCLOSE THE INFORMATION. UNAUTHORIZED REPRODUCTION OR USE OF THE INFORMATION IS PROHIBITED. THIS DOCUMENT IS TO BE RETURNED TO GARDNER DENVER, INC. UPON THE COMPLETION OF THE PURPOSE FOR WHICH IT IS LOANED OR UPON REQUEST.	
	DIMENSIONING AND TOLERANCING PER ASME Y14.5M-1994	
THIRD ANGLE PROJECTION	HEAT TREATMENT	ENG. REF.
	Gardner Denver Gardner Denver Inc. Peachtree City, GA	
DWN BY SLM 11/22/04 CKD BY SM 11/22/04	TITLE OUTLINE-BARE UNIT HF406 HORIZ	PART NO. 307HXC800
SCALE 1/2	SHEET 1 OF 1	REV A