

CONSTRUCTION	ROTATION	DISCHARGE PORT
HORIZONTAL-RIGHT	CLOCKWISE [CW]	BOTTOM
	COUNTER-CLOCKWISE [CCW]	TOP



# C. Emery Nelson, Inc.

INDUSTRIAL AND POWER PLANT EQUIPMENT

7631 Commerce Street, Hamel, MN 55340  
Ph: 763/420-3844 Fax: 763/420-2542

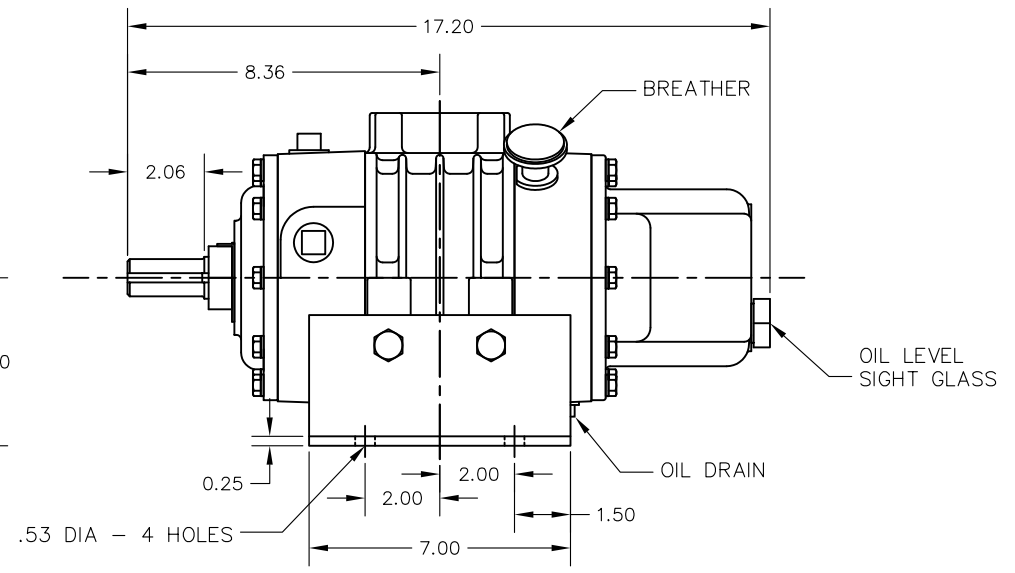
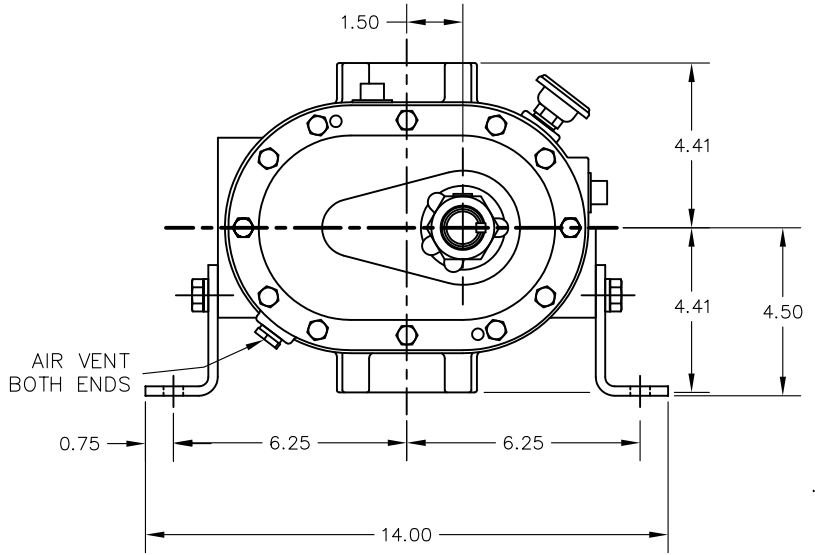
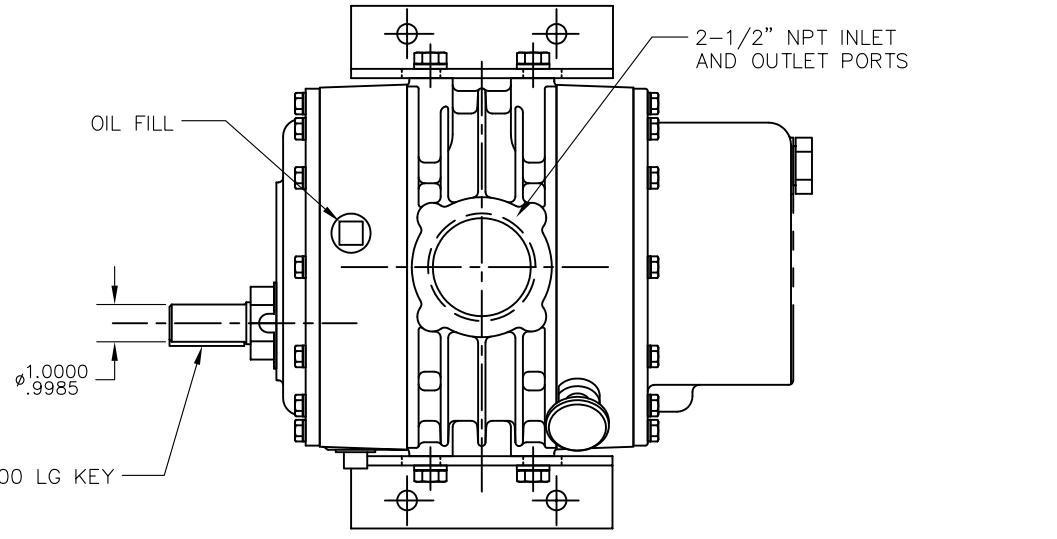

ESTIMATED WEIGHT - 120 LBS

NOTE: DIMENSIONS ARE +/- .06 INCHES UNLESS OTHERWISE SPECIFIED

CONFIDENTIAL - THE INFORMATION CONTAINED IN THIS DOCUMENT IS THE PROPERTY OF GARDNER DENVER MACHINERY INC. IT IS NOT FOR PUBLIC DISCLOSURE. POSSESSION OF THE INFORMATION DOES NOT CONVEY ANY RIGHT TO LOAN, SELL OR DISCLOSE THE INFORMATION. UNAUTHORIZED REPRODUCTION OR USE OF THE INFORMATION IS PROHIBITED. THIS DOCUMENT IS TO BE RETURNED TO GARDNER DENVER MACHINERY INC. UPON COMPLETION OF THE PURPOSE FOR WHICH IT IS LOANED OR UPON REQUEST.

LET.	REVISION	DATE	DR.	CK.	LET.	REVISION	DATE	DR.	CK.	LET.	REVISION	DATE	DR.	CK.
A	RELEASED (C/M 1018300)													
B	WAS 1.75 LG. ECN 1027922	10/12/05	TWT	RS										



TAP DRILL DEPTHS ARE MAXIMUM. FULL THD. DEPTHS ARE MINIMUM.				FINISH OF CHAMFERS & FILLETS TO CONFORM TO ROUGHEST ADJACENT AREA				SURFACE ROUGHNESS MAX. PER ASA SPEC.			
TOLERANCES: UNLESS OTHERWISE SPECIFIED				HEAT TREAT SPEC.				FOR ALL CURRENT SPECIFICATIONS REFER TO BILL OF MATERIAL			
DECIMAL .XX ± .02		.XXX ± .010		DR. SLM 10/14/03		MET. APP.		NAME OUTLINE-BARE UNIT		MODEL 3004 HR	
NON-DECIMAL ± 1/16		ANGLES ± 1'		CK. SM 10/14/03		ENG. APP.		SCALE 3/8		306GGB800	
SHEET 1 OF 1				-				FILE NO. C CAD/CAM			