



C. Emery Nelson, Inc.

INDUSTRIAL AND POWER PLANT EQUIPMENT

7631 Commerce Street, Hamel, MN 55340
Ph: 763/420-3844 Fax: 763/420-2542

**Gardner
Denver**

PD BLOWERS & VACUUM PUMPS
LEGEND "S" SERIES BLOWERS | 6" GEAR DIAMETER

Parts List, Operating & Service Manual

LEGEND "S" SERIES 6" GEAR DIAMETER



SB-7-635
Version 01
April 23, 2018

Models

GAF__S_

**MAINTAIN BLOWER RELIABILITY AND PERFORMANCE
WITH GENUINE GARDNER DENVER
PARTS AND SUPPORT SERVICES**

Factory genuine parts, manufactured to design tolerances, are developed for optimum dependability - - - specifically for your blower. Design and material innovations are born from years of experience with hundreds of different blower applications. When you specify factory genuine parts you are assured of receiving parts that incorporate the most current design advancements manufactured in our state-of-the-art blower factory under exacting quality standards.

Your **AUTHORIZED DISTRIBUTOR** offers all the backup you require. A worldwide network of authorized distributors provides the finest product support in the blower industry.

1. Trained technical representatives to assist you in selecting the correct replacement parts.
2. Complete inventory of new machines and new, genuine factory parts.
3. A full line of factory tested AEON® PD blower lubricants, specifically formulated for optimum performance in all blowers.
4. Authorized distributor service technicians are factory-trained and skilled in blower maintenance and repair. They are ready to respond and assist you by providing fast, expert maintenance and repair service.

INSTRUCTIONS FOR DETERMINING BLOWER CONFIGURATION

1. Face the blower drive shaft.
2. In a **VERTICAL** configuration, air flow is horizontal.
3. In a **HORIZONTAL** configuration, air flow is vertical.
4. In a vertical configuration, a **BOTTOM HAND** exists when the drive shaft is below the horizontal center line of the blower. A **TOP HAND** exists when the drive shaft is above the horizontal center line of the blower.
5. In a horizontal configuration, a **RIGHT HAND** exists when the drive shaft is to the right of the vertical center line of the blower. A **LEFT HAND** exists when the drive shaft is to the left of the vertical center line of the blower.

INSTRUCTIONS FOR ORDERING REPAIR PARTS

For pricing, and ordering information contact your nearest **AUTHORIZED FACTORY DISTRIBUTOR**. When ordering parts, specify Blower **MODEL** and **SERIAL NUMBER** (see nameplate on unit).

Rely upon the knowledge and experience of your **AUTHORIZED DISTRIBUTOR** and let them assist you in making the proper parts selection for your blower.

To Contact Gardner Denver or locate your local distributor:
Visit: www.gardnerdenver.com/gdproducts

Or

Call: - (800)372-2222



GARDNER DENVER LUBRICANT ORDER INFORMATION

Re-order Part Numbers for Factory Recommended Lubricants.

Gear and Drive End

AEON PD Synthetic Lubricant, AEON PD-XP—Extreme Duty Synthetic Lubricant or
AEON PD-FG—Food Grade Synthetic Lubricant

AEON PD Synthetic Lubricant

<u>Description</u>	<u>Part Number</u>
1 Quart	28G23
Case/12Quarts	28G24
1 Gallon Container	28G40
Case/6 Gallons	28G41
5 Gallon Pail	28G25
55 Gallon Drum	28G28

AEON PD-XD – Extreme Duty Synthetic Lubricant

<u>Description</u>	<u>Part Number</u>
1 Quart	28G46
Case/12Quarts	28G47
1 Gallon Container	28G42
Case/6 Gallons	28G43
5 Gallon Pail	28G44
55 Gallon Drum	28G45

AEON PD-FG – Food Grade Synthetic Lubricant

<u>Description</u>	<u>Part Number</u>
1 Quart	28H97
Case/12Quarts	28H98
1 Gallon Container	28H333
Case/6 Gallons	28H334
5 Gallon Pail	28H99
55 Gallon Drum	28H100

Drive End

AEON PD Grease

<u>Description</u>	<u>Part Number</u>
Case/10 Tubes (14oz/Tube)	28H283

Call your local Gardner Denver Distributor to place your order for Gardner Denver lubricants.
Your Authorized Gardner Denver Distributor is:

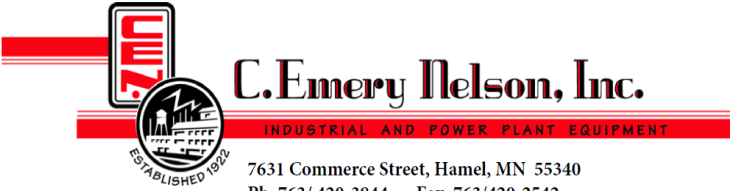

C. Emery Nelson, Inc.
INDUSTRIAL AND POWER PLANT EQUIPMENT

7631 Commerce Street, Hamel, MN 55340
Ph: 763/ 420-3844 Fax: 763/420-2542

FOREWORD

Sutorbilt® blowers are the result of advanced engineering and skilled manufacturing. To be assured of receiving maximum service from this machine, the owner must exercise care in its operation and maintenance. This manual is written to give the operator and maintenance department essential information for day-to-day operation, maintenance and adjustment. Careful adherence to these instructions will result in economical operation and minimum downtime.



Danger is used to indicate the presence of a hazard which will cause severe personal injury, death, or substantial property damage if the warning is ignored.



Warning is used to indicate the presence of a hazard which can cause severe personal injury, death, or substantial property damage if the warning is ignored.



Caution is used to indicate the presence of a hazard which will or can cause minor personal injury or property damage if the warning is ignored.

NOTICE

Notice is used to notify people of installation, operation or maintenance information which is important but not hazard-related.

SAFETY PRECAUTIONS

Safety is everybody's business and is based on your use of good common sense. All situations or circumstances cannot always be predicted and covered by established rules. Therefore, use your past experience, watch out for safety hazards and be cautious. Some general safety precautions are given below:



Failure to observe these notices could result in injury to or death of personnel.

- **Keep fingers and clothing away** from revolving fan, drive coupling, etc.
- **Do not use the air discharge** from this unit for breathing – not suitable for human consumption.
- **Do not loosen or remove** the oil filler plug, drain plugs, covers or break any connections, etc., in the blower air or oil system until the unit is shut down and the air pressure has been relieved.
- **Electrical shock** can and may be fatal.
- **Blower unit must be grounded** in accordance with the National Electrical Code. A ground jumper equal to the size of the equipment ground conductor must be used to connect the blower motor base to the unit base.
- **Open main disconnect switch**, tag and lockout before working on the control.
- **Disconnect the blower** from its power source, tag and lockout before working on the unit – this machine may be automatically controlled and may start at any time.



Failure to observe these notices could result in damage to equipment.

- **Stop the unit** if any repairs or adjustments on or around the blower are required.
- **Disconnect the blower** from its power source, tag and lockout before working on the unit – this machine maybe automatically controlled and may start at any time.
- **Do not exceed** the rated maximum speed shown on the nameplate.
- **Do not operate unit** if safety devices are not operating properly. Check periodically. **Never bypass safety devices.**

TABLE OF CONTENTS

MAINTAIN BLOWER RELIABILITY AND PERFORMANCE.....	2
FOREWORD	4
SAFETY PRECAUTIONS.....	5
SUTORBILT LEGEND SERIES BLOWERS	8
INTRODUCTION.....	9
SECTION 1, EQUIPMENT CHECK.....	10
SECTION 2, INSTALLATION	12
AIR FILTERS AND FILTER SILENCERS	16
SECTION 3, LUBRICATION	17
RECOMMENDED LUBRICANT	20
SECTION 4, OPERATION	22
SECTION 5, TOOLS – DISASSEMBLY/ASSEMBLY/SPECIAL	25
SECTION 6, ASSEMBLY INSTRUCTIONS	28
SECTION 7, SPECIAL TOOLS REQUIRED	29
SECTION 8, DISASSEMBLY INSTRUCTIONS	49
SECTION 9, PARTS LIST	Error! Bookmark not defined.
WARRANTY	59

INDEX

AIR FILTERS AND FILTER SILENCERS	17	LOCATION.....	13
ASSEMBLY INSTRUCTIONS, SECTION 6	29	LUBRICATAION, SECTION 3	18
ASSEMBLY TOOLS (BASIC.....)	29	MOUNTING CONFIGURATIONS	13
ASSEMBLY TOOLS (SPECIAL	27, 28	OPERATION, SECTION 4	
BEARING HOUSING REMOVAL.....	37	OPERATION.....	23
BEARING RETAINER REMOVAL	34	PARTS LIST, SECTION 9	52
BLOWER STARTUP CHECKLIST	24	PIPING.....	15
CYLINDER INSTALLATION.....	49	PULLER PLATE INSTALLATION	36
DISASSEMBLY INSTRUCTIONS, SECTION 8	50	RECOMMENDED LUBRICANT	21
DISASSEMBLY INSTRUCTIONS	50	REMOVING PROTECTIVE MATERIALS	11
DISASSEMBLY TOOLS (BASIC.....)	26	REPOSITIONING THE MOUNTING FEET	13
DRIVE COVER REMOVAL	35	ROTOR INSTALLATION.....	49
DRIVE END LUBRICATION.....	18, 19	SAFETY PRECAUTIONS	5
DRIVE INSTALLATION.....	14	SAFETY PRECAUTIONS	25
SECTION 1 EQUIPMENT CHECK	11	SEAL INSTALLATION (LIP SEALS	45
FLANGE NUT REMOVAL	32	SEAL INSTALLATION (MECHANICAL SEALS	45
FOOT AND LIFTING LUG REMOVAL (DRIVE END)	36	SECTION 6 ASSEMBLY INSTRUCTIONS	29
FOUNDATIONS.....	13	SLINGER REMOVAL (DSL UNITS ONLY).....	35
GEAR COVER REMOVAL.....	32	SPECIAL TOOLS REQUIRED, SECTION 7	30
GEAR END LUBRICATION	19	STORAGE	11
GEAR REMOVAL.....	33	TROUBLE SHOOTING	25
INSTALLATION, SECTION 2	13	WARRANTY.....	59
INTRODUCTION.....	10		
LIMITATIONS.....	23		

LIST OF ILLUSTRATIONS

FIGURE 2-1 – BLOWER MOUNTING CONFIGURATION.....	13
FIGURE 2-2 – BELT DRIVE OVERHUNG LOAD CALCULATIONS	15
FIGURE 3-1 - LUBRICATION	17
FIGURE 3-2 – APPROXIMATE OIL CAPACITIES.....	18
FIGURE 3-3 – AEON PD SYNTHETIC LUBRICANT	20
FIGURE 3-4 – SYNTHETIC LUBRICANT CHART.....	20
FIGURE 3-5 – LUBRICATION RECOMMENDATION.....	21
FIGURE 4- 1– MAXIMUM OPERATING LIMITATIONS.....	22
FIGURE 7- 1 – PULLER PLATE	29
FIGURE 7- 2 – SEAL DRIVE	29
FIGURE 7- 3 – MECHANICAL SEAL INSTALLATION TOOL.....	30
FIGURE 7- 4 – BEARING PRESS TOOL – MECHANICAL SEAL UNITS	30
FIGURE 8- 1	49
FIGURE 8- 2	50
FIGURE 8- 3	50

SUTORBILT LEGEND SERIES BLOWERS MATRIX/MENU

NOTICE TO CUSTOMER – To find the construction options for Your blower unit, FILL IN THE BALANCE OF LETTERS OR NUMBERS FROM YOUR UNIT NAMEPLATE

G A S

COLUMN NUMBER: 1 2 3 4 5 6 7

FOLLOW THE LINE DOWN AND OVER FROM EACH SPACE THUS FILLED IN TO FIND THE APPROPRIATE CONSTRUCTION OPTION WITH WHICH YOUR MACHINE IS EQUIPPED.

COLUMN 1 – BASIC DESIGNATOR

COLUMN 2 – PRODUCT FAMILY

COLUMN 3 – GEAR DIAMETER

F	6"
---	----

COLUMN 4 – CASE LENGTH

- L - Low Pressure
- M - Medium Pressure
- H - High Pressure

COLUMN 5 – CONFIGURATION

- A Vertical-Top Hand -Central Timed
- B Vertical-Bottom Hand – Central Timed
- C Horizontal – Left Hand – Central Timed
- D Horizontal – Right Hand – Central Timed

COLUMN 6 – DESIGN VERSION

COLUMN 7 – ADDITIONAL DESCRIPTION

	<u>SEALS</u>	<u>CLEARANCES</u>	<u>LUBRICATION</u>
A.	Lip	Standard	Grease-Splash
B.	Mechanical	Standard	Grease-Splash
C.	Lip	High Temperature	Grease-Splash
D.	Lip	Standard	Dual-Splash
E.	Mechanical	Standard	Dual-Splash
F.	Lip	High Temperature	Dual-Splash
G.	Mechanical	High Temperature	Dual-Splash

INTRODUCTION

YOUR KEY TO TROUBLE FREE SERVICE

Thank you for investing in Gardner Denver quality. The Gardner Denver reputation for rugged dependability has been earned by over 50 years of service in demanding, industrial operations where downtime cannot be tolerated and efficient blower performance is expected.

Your Gardner Denver Sutorbilt blower is a precision engineered blower that has been carefully manufactured and thoroughly tested at the state-of-the art Gardner Denver Blower Factory in Sedalia, Missouri.

As with other precision machinery, there are several relatively simple installation, operation and maintenance procedures that you must observe to assure optimum blower performance. There is no guesswork in the manufacture of your highly advanced Sutorbilt blower and there must be none in preparing the blower to get the job done in the field.

The purpose of this manual is to help you properly install, operate and maintain your Sutorbilt blower. It is essential that you review all sections of this manual in preparation for installing your blower. Follow the instructions for installing your blower. Follow the instructions carefully and you will be rewarded with trouble-free Gardner Denver Sutorbilt service year in and year out.

SECTION 1 EQUIPMENT CHECK

Before uncrating, check the packing slip carefully to be sure all the parts have been received. All accessories are listed as separate items on the packing slip, and small important accessories such as relief valves can be overlooked or lost. After every item on the packing slip has been checked off, uncrate carefully.

NOTICE

Register a claim with the carrier for lost or damaged equipment.



Customers are cautioned to provide adequate protection, warning and safety equipment necessary to protect personnel against hazards involved in installation and operation of this equipment in the system or facility.

STORAGE

Your Gardner Denver Blower was packaged at the factory with adequate protection to permit normal storage for up to six (6) months.

If the unit is to be stored under adverse conditions or for extended periods of time, the following additional measures should be taken to prevent damage.

1. Store the blower in a clean, dry, heated (if possible) area.
2. Make certain inlet and discharge air ports are tightly covered to prevent foreign material from entering the air box.
3. All exposed, non-painted surfaces should be protected against rust and corrosion.
4. Provide adequate protection to avoid accidental mechanical damage.
5. In high humidity or corrosive environments, additional measures may be required to prevent rusting of the blower internal surfaces.
6. To prevent rusting of gears, bearings, etc., the oil reservoirs may be filled with normal operating oil.



Before running the blower, drain the oil and replace to the proper operating level with clean, fresh lubricant.

7. Rotate the blower shaft (10 to 25 turns) weekly during storage. Inspect the blower shaft (near the shaft seal area) monthly and spray with rust inhibitor if needed.
8. For long term storage (over six (6) months), contact Gardner Denver Compressor Division Customer Service for recommendations.

REMOVING PROTECTIVE MATERIALS

The shaft extension is protected with rust inhibitor which can be removed with any standard solvent.



Follow the safety directions of the solvent manufacturer.

Blower inlet and outlet are temporarily capped to keep out dirt and other contaminants during shipment. These covers must be removed before start-up.

The internal surfaces of all Sutorbilt units are mist sprayed with a rust preventative to protect the machine during shipment. Remove this film upon initial startup, using any commercial safety solvent. Position the blower so that the inlet and discharge connections are in the vertical position (vertical airflow). On vertically mounted units, it will be necessary to lay the unit on its side supporting the ends of the unit so as not to restrict the port on the bottom side. Place a shallow pan on the under side of the unit. With the blower disconnected from power, spray the solvent in the top port, rotating the impellers by spinning the shaft manually. Continue this procedure until the unit is visibly clean.



Rotating components will cause severe injury in case of personal contact. Keep hands and loose clothing away from blower inlet and discharge ports.

SECTION 2 INSTALLATION

LOCATION

Install the blower in a well lit, clean dry place with plenty of room for inspection and maintenance.

FOUNDATIONS

For permanent installation we recommend concrete foundations be provided, and the equipment should be grouted to the concrete. It is necessary that a suitable base be used, such as a steel combination base under blower and motor, or a separate sole plate under each. Before grouting, equipment must be leveled, free of all strains, and anchored so no movement will occur during setting of grout. After grout has completely hardened, a recheck is necessary to compensate for shrinkage, etc. If required, add shims under blower feet after final tightening of foundation anchor bolts to remove strain from the blower housing.

Where jack screws or wedges are used during grouting, they must be backed off and wedges removed before final tightening of anchor bolts. Refer to grouting instructions.

Where a concrete foundation is not feasible, care must be taken to insure that equipment is firmly anchored to adequate structural members, restricting movement and vibration.

MOUNTING CONFIGURATIONS

The blower flex-mount design enables horizontal and vertical mounting configurations with top or bottom hand, right or left hand shaft positioning. The units are center timed allowing rotation in either direction (refer to Figure 2-1).

REPOSITIONING THE MOUNTING FEET.

1. Position the mounting feet to the desired location and snug the capscrew.
2. Place the blower on its feet on a flat surface.
3. Loosen mounting feet capscrews and level unit up. The bench or blower base flatness should be within .002 of an inch.

NOTICE

If the unit is not flat within .002 of an inch, it will be necessary to shim the blower feet at installation.
--

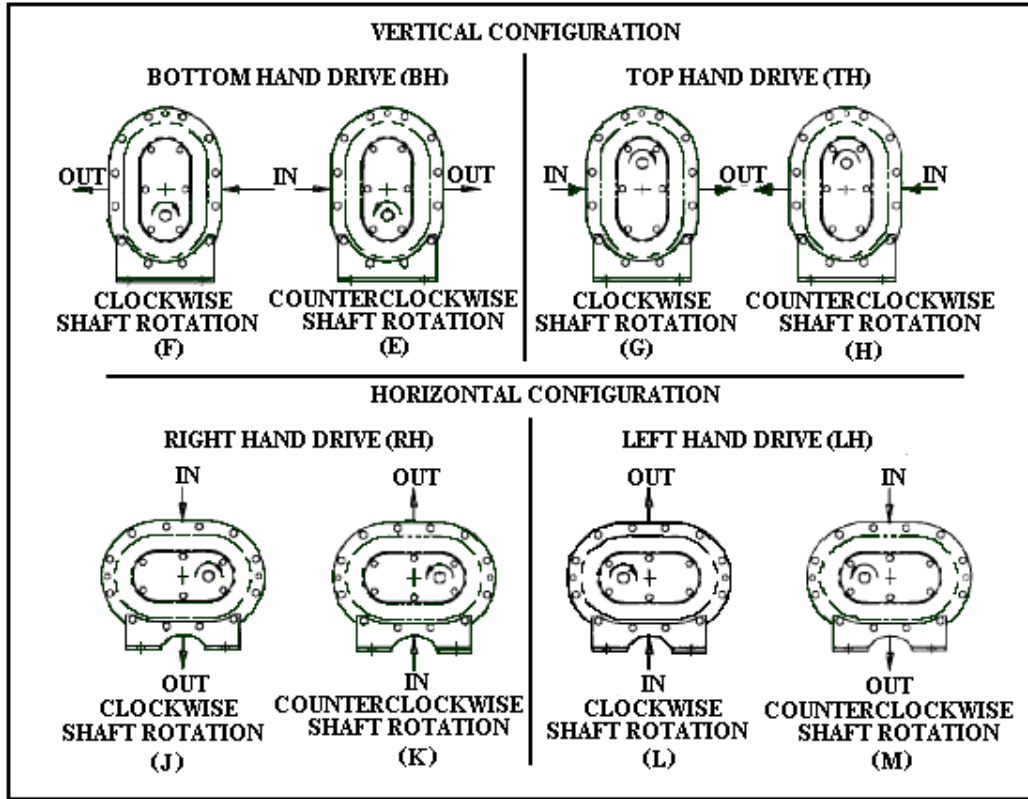

FIGURE 2-1 – BLOWER MOUNTING CONFIGURATIONS

4. Secure the mounting feet capscrews to the torque value.

NOTICE

When changing mounting configuration, it may be necessary to reposition breather/oil fill (B), oil level gauge (H) and drain plug (A). Refer to Figure 3-1, page 17, for correct location.

DRIVE INSTALLATION

When selecting a V-belt drive, check to be sure the shaft overhung load limitation is not exceeded. Refer to FIGURE 2-2, page 15, for overhung load calculations and limitations.

Belt drives must be carefully aligned. Motor and blower pulleys must be parallel to each other and in the same plane within 1/32 inch. Belt tension should be carefully adjusted to the belt manufacturer's recommendation using a belt tension gauge. Check tension frequently during the first day of operation.

⚠ WARNING

Over tightening belts leads to heavy bearing loads and premature failure.

On the direct connected units, alignment and lubrication of couplings to specifications of the coupling manufacturer is very important. When mounted drives are supplied from the factory proper alignment has been established before shipment. However, during shipping, handling and installation, it is likely that the alignment has been disturbed and final adjustment must be made before startup.



Exceeding overhung load limitations leads to unwarrantable premature bearing failure and shaft breakage.

The location of the sheave on the blower shaft greatly affects the stress in the shaft. The optimum blower sheave positioning is as close as possible to the blower drive cover, not to exceed dimension "C" in Drive Shaft Illustration, FIGURE 2-2, page 15

The calculated shaft moment must not exceed the maximum allowable moment listed in Maximum Allowable Moment Chart, FIGURE 2-2 page 15. If the calculated shaft moment exceed the maximum allowable moment:

- Increase Sheave Diameters to Reduce Belt Pull
- Use Jackshaft Drive
- Use Direct Coupled or Gearbox Drive

To calculate shaft moment for a given V-Belt Drive Arrangement:

1. Use the formula for Calculation of Belt Pull, FIGURE 2-2, page 15, to calculate belt pull. Refer to Arc of Contact Factor Chart, Figure 2-2, page 15.
2. Insert the calculated belt pull into the formula for Calculation of Shaft Moment, FIGURE 2-2, page 15 to arrive at the calculated shaft moment.

PIPING

Inlet and discharge connections on all blowers are large enough to handle maximum volume with minimum friction loss. Reducing the pipe diameter on either inlet or discharge will only create additional line loss and increase the overall pressure differential. Excessive weight of piping and fittings will cause internal misalignment and premature wear. Never allow the blower to carry the weight of the pipe. If possible, a spool or sleeve-type expansion joint should be installed between the unit and the piping. Where a flexible connection is not practical, the weight of the rigid connection must be separately supported.

All system piping must be cleaned internally before connecting to the blower.



Sutorbilt blowers are shipped dry from the factory. Do not attempt to operate the blower before following proper lubrication instructions. Permanent damage to the gears, bearings and seals will occur.

Gear Diameter (Inches)	GREASE SPLASH Dimensions (Inches)			Maximum Allowable Moment (LB-IN)
	A	B	C (Max)	
6	4.08	1.14	.38	1788

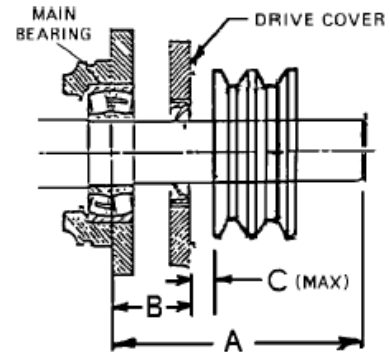

MAXIMUM ALLOWABLE MOMENT

Gear Diameter (Inches)	DUAL SPLASH LUBE Dimensions (Inches)			Maximum Allowable Moment (LB-IN)
	A	B	C (Max)	
6	4.08	1.14	.38	1788

MAXIMUM ALLOWABLE MOMENT

Z	Ac	Z	Ac	Z	Ac	Z	Ac	Z	Ac	Z	Ac
0.000	1.000	0.250	0.966	0.500	0.926	0.750	0.879	1.000	0.823	1.250	0.751
0.025	0.997	0.275	0.962	0.525	0.922	0.775	0.874	1.025	0.816	1.275	0.742
0.050	0.994	0.300	0.958	0.550	0.917	0.800	0.869	1.050	0.810	1.300	0.734
0.075	0.990	0.325	0.954	0.575	0.913	0.825	0.864	1.075	0.803	1.325	0.725
0.100	0.987	0.350	0.951	0.600	0.908	0.850	0.858	1.100	0.796	1.350	0.716
0.125	0.983	0.375	0.947	0.625	0.904	0.875	0.852	1.125	0.789	1.375	0.706
0.150	0.980	0.400	0.943	0.650	0.899	0.900	0.847	1.150	0.782	1.400	0.697
0.175	0.977	0.425	0.939	0.675	0.894	0.925	0.841	1.175	0.774	1.425	0.687
0.200	0.973	0.450	0.935	0.700	0.889	0.950	0.835	1.200	0.767		
0.225	0.969	0.475	0.930	0.725	0.884	0.975	0.829	1.225	0.759		

ARC OF CONTACT FACTORS

Belt Pull = $\frac{2.5 - A_c}{A_c} \times \frac{125954 \times H_p \times S.F.}{D \times RPM}$

Key:

- A_c = Arc of Contact Factor (Refer to Arc of Contact Factor Chart above)
- H_p = Blower Horsepower for Operating Conditions
- S.F. = Actual Drive Service Factor
- D = Blower Sheave Pitch Diameter in Inches
- RPM = Blower Sheave Speed
- Z = $\frac{\text{Large Sheave Pitch Diameter (in)} - \text{Small Sheave Pitch Diameter (in)}}{\text{Sheave Center Distance (in)}}$

CALCULATION OF BELT PULL

$$\text{Shaft Moment (LB-IN)} = \text{Belt Pull} \times \left[B + C + \left(\frac{\text{Sheave Width}}{2} \right) \right]$$

CALCULATION OF SHAFT MOMENT

FIGURE 2-2 – BELT DRIVE OVERHUNG LOAD CALCULATIONS

AIR FILTERS AND FILTER SILENCERS



Servicing the air filters is one of the most important maintenance operations to be performed to insure long blower life.

Servicing frequency of filter elements is not time predictable. A differential pressure indicator, with a continuous gauge reading, should be installed across the inlet filter. It will tell how much of the service life of the filter element has been used. It will also eliminate both premature filter servicing and premature blower failure due to a plugged filter when the filter pressure drop is used to establish maintenance points. In all cases refer to the filter manufacturer's service instructions. Due to the many types of filters, it is not practical to give specific instructions covering all models.

NOTICE

No matter what type of filter is used, always make sure all seats, gaskets, clamps and hose connections on the filter and inlet line are absolutely air tight. Each time the filter is serviced, inspect interior of the blower for dirt.

**SECTION 3
LUBRICATION**

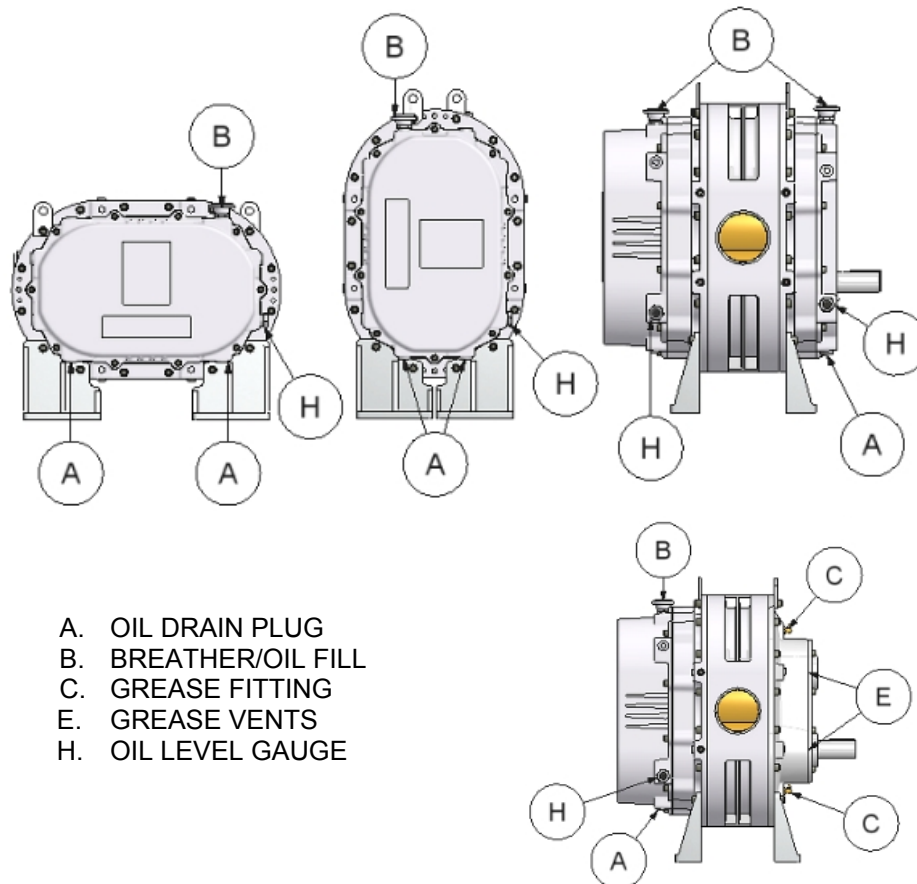

FIGURE 3-1 - LUBRICATION

DRIVE END LUBRICATION (For Grease – Splash Lube Blowers)

Drive end bearings are grease lubricated at the factory with Lithium Complex based grease. **For relubrication, use Gardner Denver AEON PD Grease, Part Number 28H283.** AEON PD Grease is a high temperature, high performance grease that is formulated with antiwear additives to provide superior service under the severe operating conditions of positive displacement blowers. It contains rust inhibitors which provide excellent protection against rust and corrosion.

If you choose not to use AEON PD Grease, select compatible base grease. The grease should be NLGI Grade 2 EP, contain rust inhibitors, and be suitable for blower discharge temperatures up to 350° F (177° C). Completely clean or purge the factory--filled grease from the blower. **Do not mix different types of grease as they may not be compatible. Substitutions may cause early bearing failure.**

Re-grease bearings every 500 hours of operation. Lubricate each bearing through the grease fittings located at C in FIGURE 3-1 (2 places). When re-greasing, the old grease will be forced out of the vents (E in FIGURE 3-1). To prevent damage to seals, these vents must be open at all times.



Do not over--grease bearings as this could cause premature bearing failure.

DRIVE END LUBRICATION (For Dual Splash Lube Blowers)

At the drive end, the bearings are lubricated by the slinger, which must be on the lowest rotor when in a vertical configuration.

Approximate oil sump capacities are listed in Figure 3-2.

NOTICE
Machines are shipped without oil in the sump. Do not operate before adding lubricant.

Lubrication Instructions

Filling procedure

Refer to Figure 3-1, page 17. Remove the breather (B) from the drive cover. Add oil to the drive sump until oil reaches the center of the oil level gauge (H). Secure breather (B) in the drive cover.

Add fresh oil as required to maintain proper level. The oil level should be at the middle of the sight glass when the machine is not operating. Refer to Figure 3-2, for approximate oil capacities.

Legend “S” Series, Grease-Splash Lube Blower Oil Capacities

Approximate Sump capacity in pints or ounces							
		Vertical Configuration			Horizontal Configuration		
Series	Gear Diameter (in)	Gear End	Drive End	Total	Gear End	Drive End	Total
6	6	1.8PT (29oz)	grease	1.8PT (29oz)	4.3PT (68 oz)	grease	4.3PT (68 oz)

Note: Quantities are for purchase estimates only.

Legend “S” Series, Dual Splash Lube Blower Oil Capacities

Approximate Sump capacity in pints or ounces							
		Vertical Configuration			Horizontal Configuration		
Series	Gear Diameter (in)	Gear End	Drive End	Total	Gear End	Drive End	Total
6	6	1.8PT (29oz)	1.1PT (17 oz)	2.9PT (46 oz)	4.3PT (68 oz)	2PT (32 oz)	6.3PT (100 oz)

Note: Quantities are for purchase estimates only.

FIGURE 3- 2 – APPROXIMATE OIL CAPACITIES

GEAR END LUBRICATION (For Grease – Splash Lube and Dual Splash Lube Blowers)

At the gear end, the timing gear teeth are lubricated by being partially submerged in oil. The gear teeth serve as oil slingers for gear end bearings.

Approximate oil sump capacities are listed in Figure 3-2.



Do not overfill as this will tend to cause excessive heating of the gears and may damage the unit.

NOTICE

Machines are shipped without oil in the sump. Do not operate before adding lubricant.

LUBRICATION INSTRUCTIONS

Filling procedure Refer to FIGURE 3-1, page 17. Remove the breather (B) from the gear cover. Add oil to the gear case until oil reaches the center of the oil level gauge (H). Secure breather (B) in the gear cover.

Add fresh oil as required to maintain proper level. The oil level should be at the middle of the sight glass when the machine is not operating. Refer to Figure 3-2, page 18, for approximate oil capacities.

RECOMMENDED LUBRICANT

AEON PD Synthetic Blower Lubricant is recommended. Refer to FIGURE 3-3, for AEON PD, AEON PD-FG (Food Grade) and AEON PD-XD (Extreme Duty) part numbers. Order AEON PD from your Gardner Denver Distributor or call Gardner Denver directly.

Convenient Package Sizes	AEON PD Part No.	AEON PD-FG Part No.	AEON PD-XD Part No.
1 quart	28G23	28H97	28G46
Case 12 quarts	28G24	28H98	28G47
1 gallon	28G40	28H333	28G42
Case 6 gallons	28G41	28H334	28G43
5 gallon pail	28G25	28H99	28G44
55 gallon drum	28G28	28H100	28G45

FIGURE 3- 3 – AEON PD SYNTHETIC LUBRICANT

AEON PD is formulated especially for positive displacement blower service to provide maximum blower protection at any temperature. One fill of AEON PD will last a minimum of 4 times longer than a premium mineral oil. Refer to FIGURE 3-4.

		Ambient Temperatures			
		Less than 10° F	10°F to 32°F	32°F to 90°F	Greater than 90°F
Blower Discharge Temperature	Less than 32°F	AEON PD AEON PD-FG	AEON PD AEON PD-FG		
	32° F to 100° F	AEON PD AEON PD-FG	AEON PD AEON PD-FG	AEON PD AEON PD-FG	
	100° F to 225°F	AEON PD AEON PD-FG	AEON PD AEON PD-FG	AEON PD AEON PD-FG	AEON PD AEON PD-FG
	225° F to 300° F	AEON PD AEON PD-FG	AEON PD AEON PD-FG	AEON PD AEON PD-FG	AEON PD XD
	Greater than 300°F			AEON PD XD	AEON PD XD

FIGURE 3- 4 – SYNTHETIC LUBRICANT CHART

AEON PD Synthetic Lubricant should be drained after 6000 hours of operation. Re-fill with fresh AEON PD oil. If mineral oil is used, perform the above oil change maintenance every 1500 hours. Recommended service intervals are for normal blower operating conditions. Severe operating conditions may warrant more frequent oil changes. Laboratory analysis of lubricant should be used to help determine the optimum oil change interval.

For best performance and equipment protection, use AEON PD Synthetic Lubricant, which has been specifically formulated for positive displacement blowers. If you choose not to use AEON PD Synthetic Blower Lubricant, select an oil with rust and oxidation inhibitors, anti-foam additives, and the viscosities listed in FIGURE 3-5. Do not use an oil that contains EP additives.

NOTICE
Flush the oil whenever a change is made from one type of oil to another.

Drain the current lubricant as thoroughly as possible. Refill with the new lubricant. Fill to normal level of the blower, which is at the middle of the sight glass when the machine is not operating. Run the blower for one hour. Shut off the blower and drain the lubricant completely. Refill the blower again with the new lubricant.

Blower Discharge Temperature	Ambient Temperature			
	Less than 10° F*	10° F to 32° F**	32° F to 90° F	Greater than 90° F
Less than 32° F (0° C)	ISO 100	ISO 100		
32° F to 100° F (0° C to 38° C)	ISO 100	ISO 100	ISO 150	
100° F to 225° F (38° C to 105° C)	ISO 100	ISO 100	ISO 150	ISO 220
225° F to 300° F (105° C to 149° C)	ISO 150	ISO 150	ISO 220	ISO 220
Greater than 300° F (149° C)			***	***

* For ambient temperatures less than 10° F, but not less than -20° F, the use of oil sump heaters, heated enclosures or synthetic lubricant is required.

** For ambient temperatures 10° F to 32° F, the use of oil sump heaters, heated enclosures or synthetic lubricant is recommended.

*** The lubricant viscosity must be 70 SUS minimum at the lubricant operating temperature.

The pour point of the lubricant should be at least 5° to 10° F below the minimum expected ambient temperature.

For continuous operation, where the lubricant temperature exceeds 200° F, synthetic lubricant is recommended.

FIGURE 3- 5 – LUBRICATION RECOMMENDATION

SECTION 4 OPERATION

Future operating problems can be avoided if proper precautions are observed when the equipment is first put into service.

Before starting under power, the blower should be turned over by hand to make certain there is no binding or internal contact.

Each size blower has limits on pressure differential, running speed and discharge temperature which must not be exceeded. These limits are shown in "Maximum Operating Limitations",

⚠ WARNING
Operating beyond the specified operating limitations will result in damage to the unit.

It is important that the pressures and temperatures are measured directly at the ports of the blower to avoid error that may be caused by intervening pipe runs, fittings, etc.

Relief valves must be used to protect against excessive pressure or vacuum conditions. These valves should be tested at initial startup to be sure they are adjusted to relieve at or below the maximum pressure differential rating of the blower.

NOTICE
Relief valves should be placed as close as possible to the blower inlet or discharge.

In some instances, pressure may be relieved at a lower point than the blower maximum in order to protect the motor or the equipment served by the blower.

Discharge temperature switches are recommended to protect against excessive inlet restriction or inlet temperatures. Check valves in the discharge line on pressure blowers and in the inlet line on vacuum blowers are recommended to protect the blower from motoring backwards when shut down under load.

LIMITATIONS

For information regarding limitations, refer to

MAXIMUM / MINIMUM OPERATING LIMITATIONS					
SIZE	RPM	PRESSURE PSI.	VAC IN HG	MAX. TEMPERATURE RISE ° F	MAX. DISCHARGE TEMPERATURE ° F
6LS	2350	7	14	160	260
6MS	2350	14	16	180	325
6HS	2350	15	16	200	340

DO NOT EXCEED THESE LIMITS

NOTICE
Blower speed, line losses, elevation, and increased inlet temperatures will affect the maximum operating limitations. The minimum RPM for the blowers is based on lubrication only. The blowers may only be operated down to the minimum RPM, when the temperature rise and discharge temperature are below the maximum limitations as shown.

FIGURE 4- 1– MAXIMUM OPERATING LIMITATIONS

The minimum RPMs for the blowers are based on lubrication only. The blowers may only be operated down to the minimum RPMs when the temperature rise and discharge temperature are below the maximum limitations as shown in Figure 4-1.

SIZE	CONFIGURATION	MINIMUM RPM
6LS, 6MS, 6HS	VERTICAL	891
6LS, 6MS, 6HS	HROIZONTAL	637

FIGURE 4- 2– MAXIMUM OPERATING LIMITATIONS

BLOWER STARTUP CHECKLIST

This startup procedure should be followed during the initial installation and after any shutdown periods or after the blower has been worked on or moved to new location. It is suggested that the steps be followed in sequence and checked off (✓) in the boxes provided.

1. Check the unit and all piping for foreign material and clean if required.
2. Check the flatness of the feet and the alignment of the drive. Feet that are bolted down in a bind can cause housing distortion and internal rubbing. Misaligned V-drives can cause the rotors to rub against the headplates and cause a reduction in the volumetric efficiency of the unit. Misaligned couplings can ruin bearings.
3. If the blower is V-belt driven, check the belt tension and alignment. Over-tensioned belts create heavy bearing/shaft loads which lead to premature failure.
4. Be sure adequate drive guards are in place to protect the operator from severe personal injury and incidental contact.
5. Check the unit for proper lubrication. Proper oil level cannot be over-emphasized. Too little oil will ruin bearings and gears. Too much oil will cause overheating and can ruin gears and cause other damage. Insure that grease lubricated bearings are properly lubricated.
6. With motor electrical power locked out and disconnected, turn the drive shaft by hand to be certain the impellers do not bind.
7. "Jog" the unit with the motor a few times to check that rotation is in the proper direction, and to be certain it turns freely and smoothly.
8. The internal surfaces of all Sutorbilt units are mist sprayed with a rust preventive to protect the machine during the shipping and installation period. This film should be removed upon initial startup.
9. Start the unit and operate 15 minutes at no load. During this time, check for hot spots and other indications of interference.
10. Apply the load and observe the operation of the unit for one hour. Check frequently during the first day of operation.
11. If malfunctions occur, do not continue to operate. Problems such as knocking rotors can cause serious damage if the unit is operated without correction.

SAFETY PRECAUTIONS

1. Do not operate blower with open inlet or outlet port.
2. Do not exceed specified vacuum or pressure limitations.
3. Do not operate above or below recommended blower speed range.
4. Blower is not to be used where non-sparking equipment is specified.
5. Do not operate without belt guard or coupling shield.



Do not exceed sheave or coupling manufacturer’s rim speed limit.

6. The blower and blower discharge piping may be extremely hot and cause skin burns on contact.



TROUBLE SHOOTING

No matter how well the equipment is designed and manufactured, there may be times when servicing will be required due to normal wear, the need for adjustment, or various external causes. Whenever equipment needs attention, the operator or repairman should be able to locate the cause and correct the trouble quickly. The Trouble Shooting Chart below is provided to assist the mechanic in those respects.

PROBLEM	POSSIBLE CAUSES	SOLUTION
Knocking	<ol style="list-style-type: none"> 1. Unit out of time. 2. Distortion due to improper mounting or pipe strains. 3. Excessive pressure differential. 4. Worn gears. 5. Worn bearings. 	<ol style="list-style-type: none"> 1. Re-time impellers 2. Check mounting alignment and relieve pipe strains. 3. Reduce to manufacturer's recommended pressure. Examine relief valve, re-set if necessary. 4. Replace timing gears. 5. Replace bearings.
Excessive blower temperature.	<ol style="list-style-type: none"> 1. Too much oil in gear case. 2. Too low operating speed. 3. Dirty air Filter. 4. Clogged filter or muffler. 5. Excessive pressure differential. 6. Worn impeller clearances. 7. Internal contact. 	<ol style="list-style-type: none"> 1. Reduce oil level. 2. Increase blower speed. 3. Clean or replace air filter 4. Remove cause of obstruction. 5. Reduce pressure differential across the blower. 6. Replace impeller. 7. Correct clearances.
Impeller end or tip drag.	<ol style="list-style-type: none"> 1. Insufficient assembled clearances. 2. Case or frame distortion. 3. Excessive operating pressure. 4. Excessive operating temperature. 	<ol style="list-style-type: none"> 1. Correct clearances. 2. Check mounting and pipe strain. 3. Remove cause. 4. Remove cause
Lack of volume.	<ol style="list-style-type: none"> 1. Slipping belts. 2. Worn clearances. 3. Dirty air filter 	<ol style="list-style-type: none"> 1. Tighten belts. 2. Re-establish proper clearances. 3. Clean or replace air filter.
Excessive bearing or gear wear.	<ol style="list-style-type: none"> 1. Improper lubrication. 	<ol style="list-style-type: none"> 1. Correct lubrication level. Replace dirty oil.
Loss of oil.	<ol style="list-style-type: none"> 1. Headplate, gear case or drive cover vents plugged. 2. Worn Seal. 	<ol style="list-style-type: none"> 1. Clean vents. 2. Replace seals.

**SECTION 5
TOOLS – DISASSEMBLY/ASSEMBLY/SPECIAL**

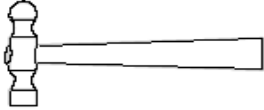
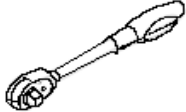
DISASSEMBLY TOOLS (BASIC)

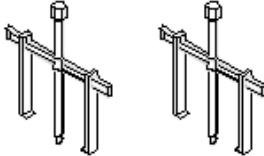
<p>Nylon Wedge</p>	
<p>Ball Peen Hammer</p>	
<p>Ratchet (or Impact Wrench)</p>	
<p>Hex Key Socket Set, 3/8" Drive (SAE)</p>	
<p>Two Jaw Pullers (2)</p>	
<p>Maintenance Kits - R&S GRS-SPL</p>	<p>305GAF6003</p>
<p>Maintenance Kits - R&S DSL</p>	<p>306GAF6003</p>

ASSEMBLY TOOLS (SPECIAL)

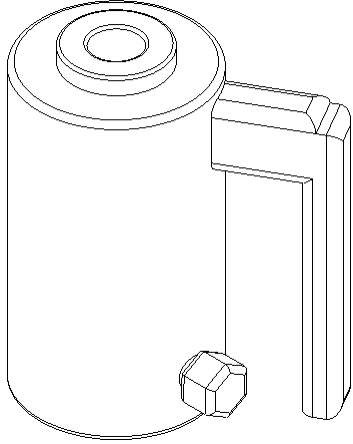
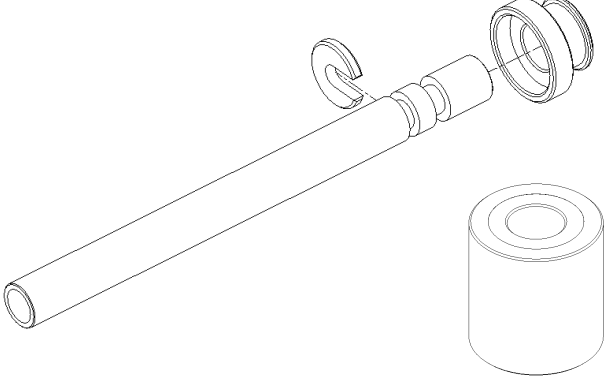
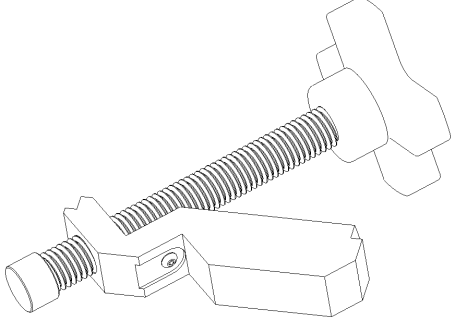
<p>(D)</p>	<p>Hollow Hydraulic Ram</p> <p>*Pressure gauge required for all hydraulic installation equipment.</p>	<p>6"</p>	<p>TEN001154</p>	
<p>(E)</p>	<p>Pull Rod & Driver Assembly Kit</p> <p>(includes gear/bearing driver)</p>	<p>6"</p>	<p>318GAF074</p>	
<p>(F)</p>	<p>* Rotor Lock Assembly (without feeler gauge)</p>	<p>6H</p>	<p>319GAF074</p>	
<p>6M</p>	<p>320GAF074</p>			
<p>6L</p>	<p>320GAF074</p>			
<p>6MQ</p>	<p>322GAF074</p>			

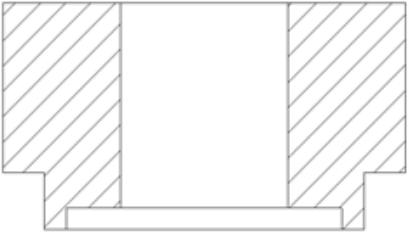
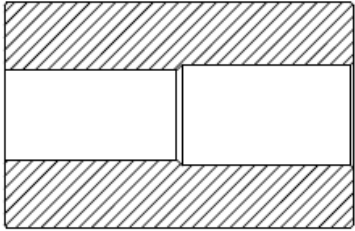

* Customers can purchase a master kit that contains all four rotor lock assembly. Part number is 300GAF6031

ASSEMBLY TOOLS (SPECIAL)

(A)	Driver, Lip Seal	6"	326GAF074	
(B)	Driver, Mech. Seal	6"	332GAF074	
(C)	Driver, Drive Bearings	6"	308GAF074	

**SECTION 6
ASSEMBLY INSTRUCTIONS**

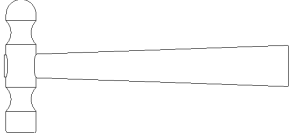
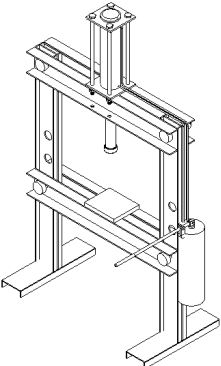
ASSEMBLY TOOLS (BASIC)

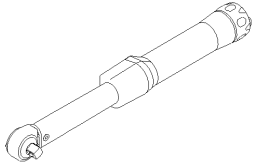
<p>Ball Peen Hammer</p>	
<p>Hydraulic Press *Pressure gauge required for all hydraulic installation equipment.</p>	
<p>Feeler Gauges (1/2" x 12") 0.004" 0.009" 0.012" 0.016" 0.019" (high temp. clearance units require stacking)</p>	
<p>Torque Wrench</p>	

**SECTION 7
SPECIAL TOOLS REQUIRED**

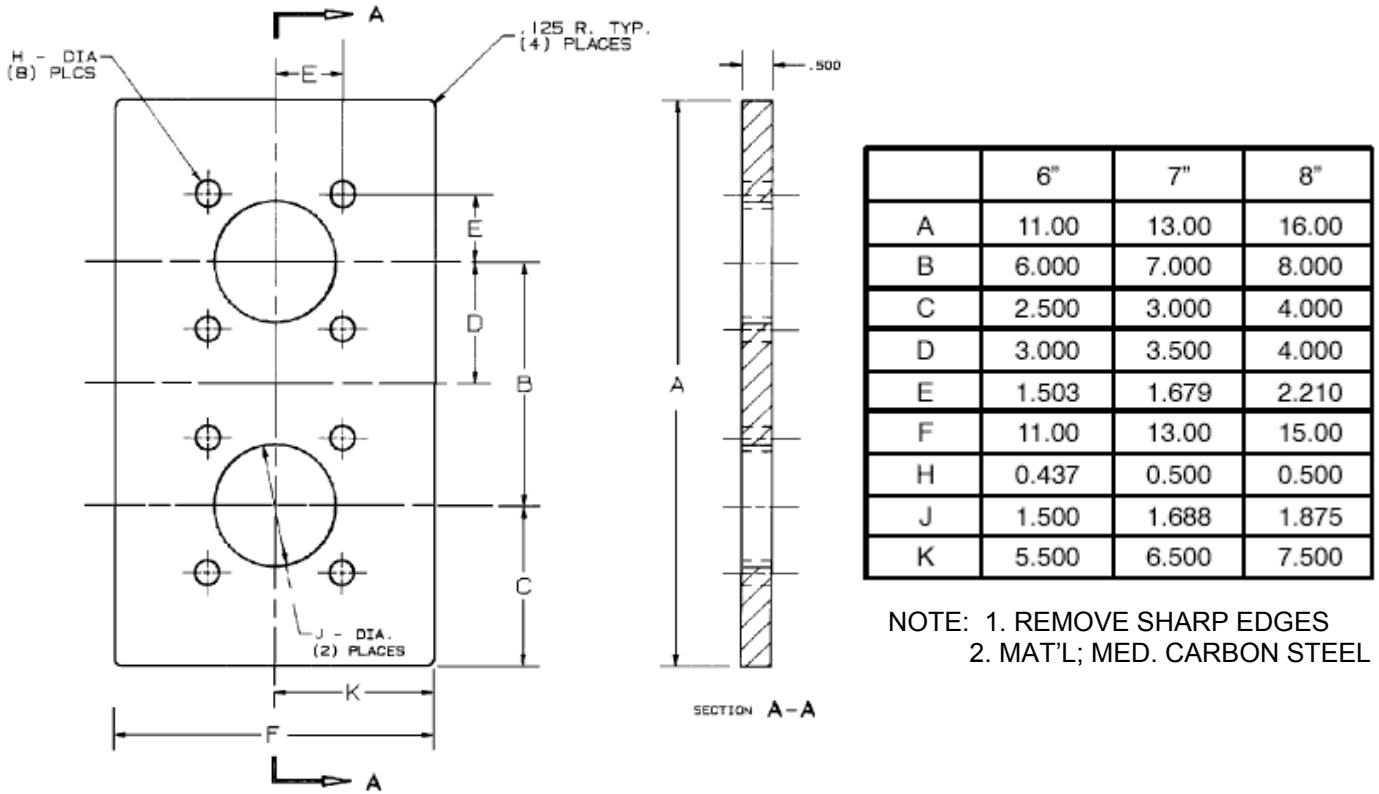
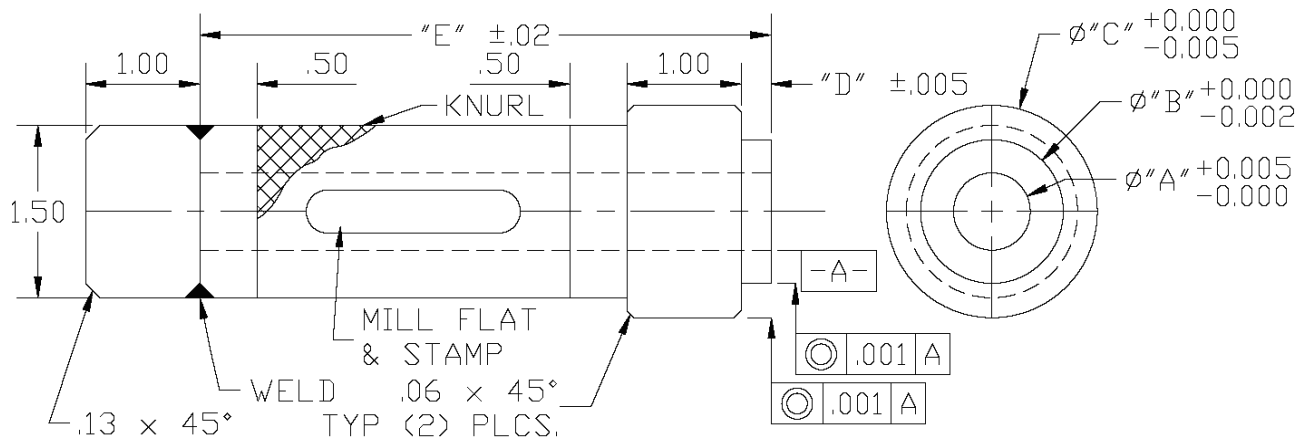
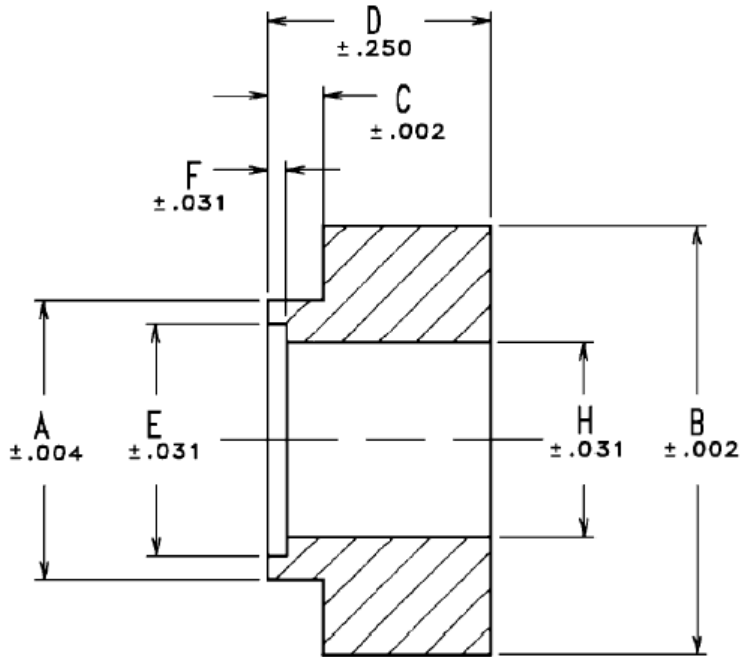

FIGURE 7-1 - PULLER PLATE



SIZE	"A"	"B"	"C"	"D"	"E"
6"	1.375	2.245	3.125	.125	5.63

FIGURE 7-2 - SEAL DRIVE



NOTE: 1. REMOVE SHARP EDGES
 2. MAT'L; 4140
 3. HEAT TREAT TO RC 48 – 52

UNIT SIZE	A	B	C	D	E	F	H
6"	2.748	3.150	0.515	1.890	2.450	0.125	1.400
7"	3.00	3.543	0.424	1.863	2.423	0.150	1.616
8"	3.250	3.938	0.407	2.000	2.800	0.150	1.813

FIGURE 7- 3 – MECHANICAL SEAL INSTALLATION TOOL

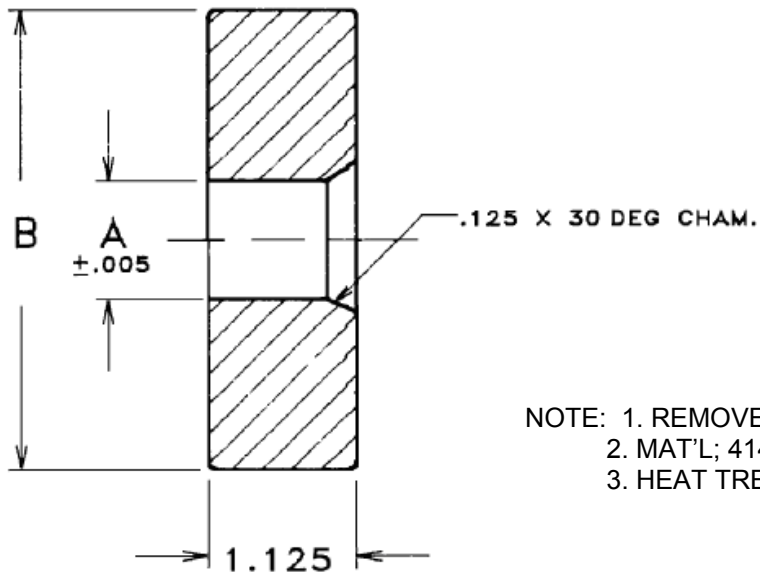

NOTE: 1. REMOVE SHARP EDGES
 2. MAT'L; 4140
 3. HEAT TREAT TO RC 52 – 56

Unit Size	A	B
6"	1.900	5.000
7"	2.087	5.500
8"	2.406	6.000

FIGURE 7- 4 – BEARING PRESS TOOL – MECHANICAL SEAL UNITS

7- 1 – Gear Cover Removal

- Drain oil by removing plug (2) from gear end cover (3).
- NOTE – For DSL units, repeat previous step to drain oil on drive end.
- Remove gear cover (3) by removing screws (30).

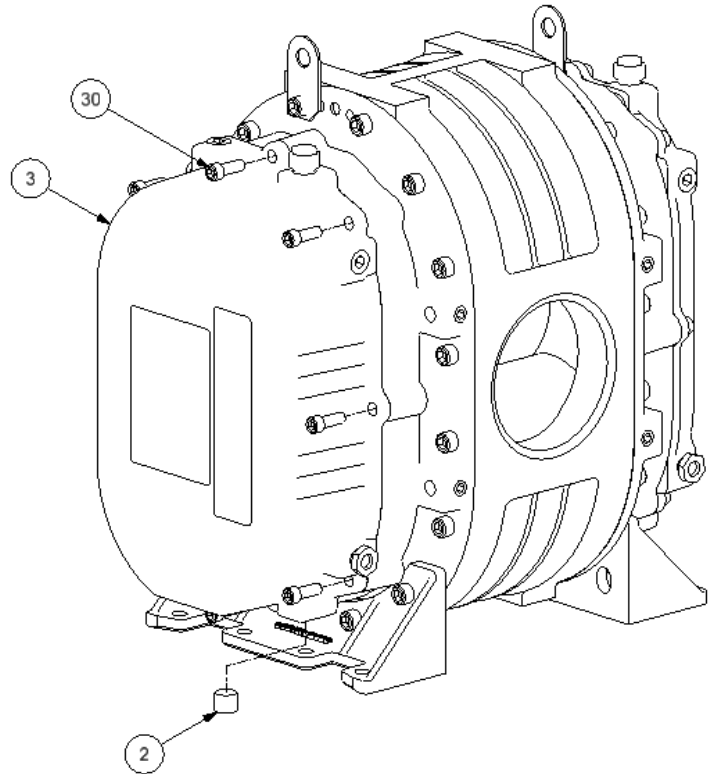

7- 2 – Flange Nut Removal

- Place a nylon wedge or shop rag between gears to stop rotation while removing flange nuts.
- Remove flange nuts (89).

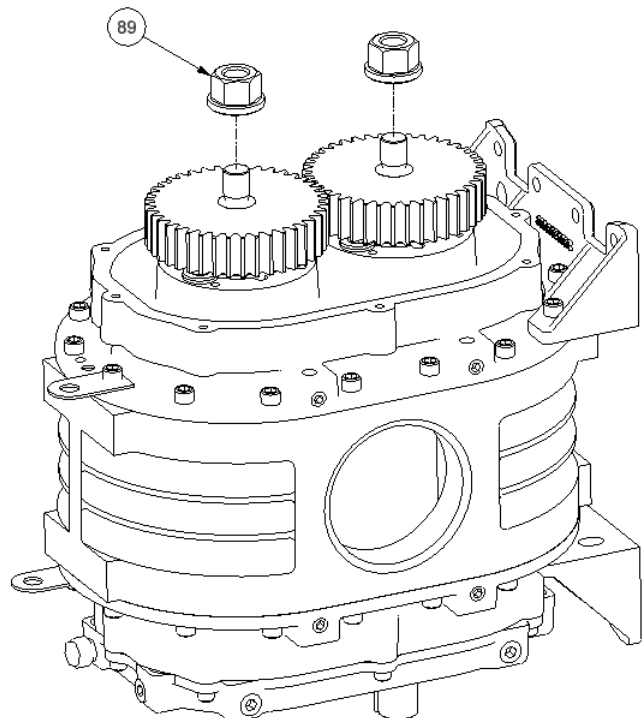

7 - 3 – Gear Removal

- Loosen flange nuts so that they are flush with end of the shafts.
- Install gear puller as shown.
- Use ratchet to tighten stud pressing against shaft and nut. (DO NOT USE IMPACT WRENCH).
- Repeat for other gear.

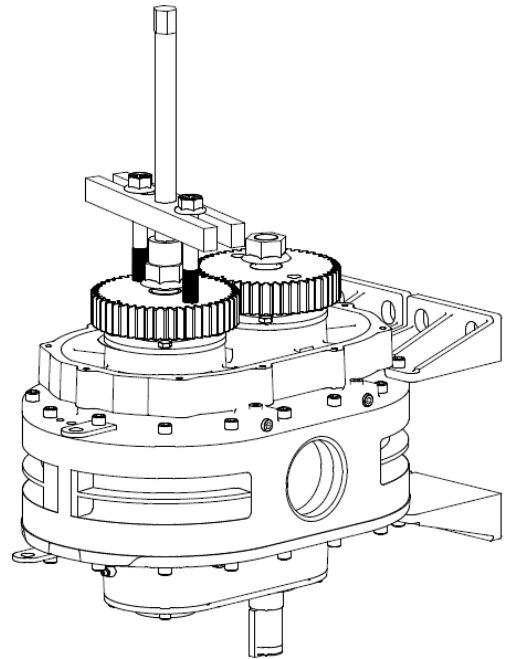

7 - 5 – Bearing Retainer Removal

- Remove screws (10) and retaining rings (12).
- Rotate unit 180° so drive end is up.

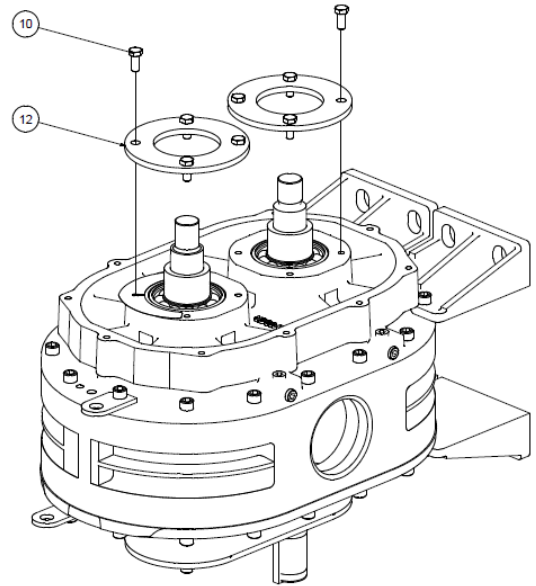

7 - 6 – Drive Cover Removal

- Remove key (25) from shaft.
- Remove drive cover (29) by removing screws (30).

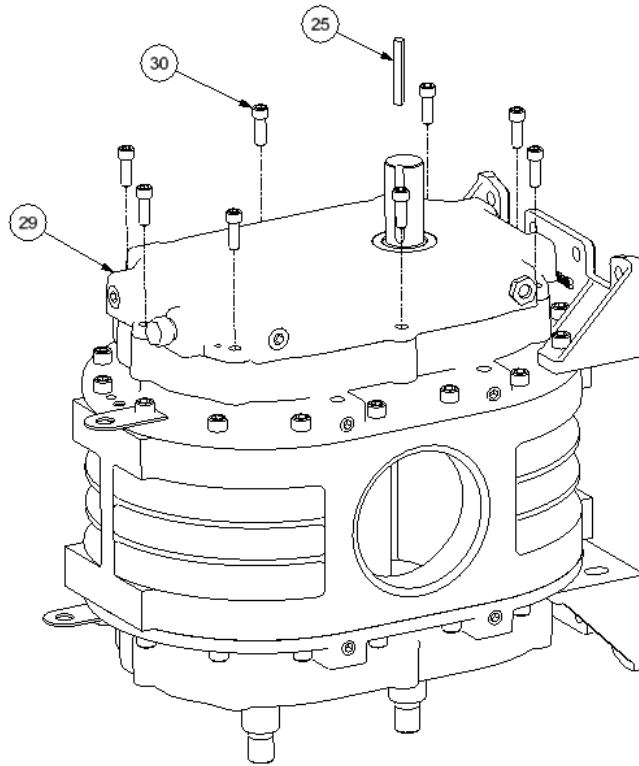

7 - 7 – Slinger Removal (DSL Units Only)

- Loosen and/or remove screws (84).
- Remove slingers (83).

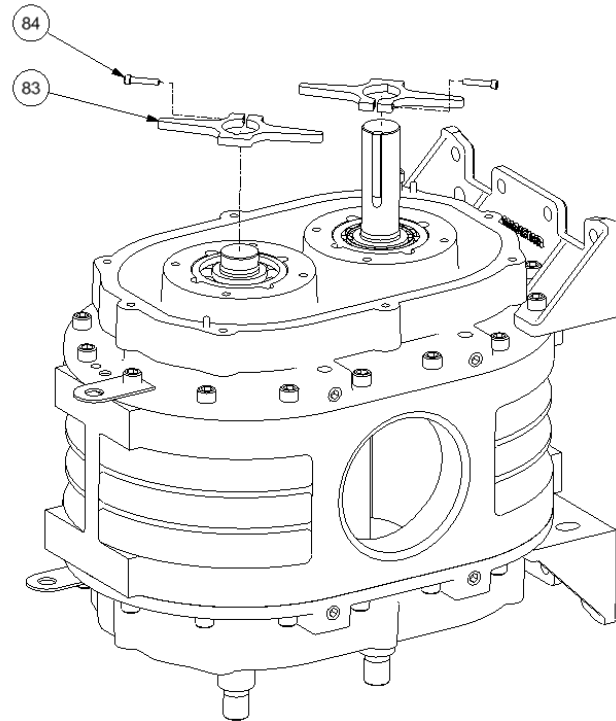

7- 8 – Foot and Lifting Lug Removal (Drive End)

- Remove lifting lug (20) and foot (17) by removing screws (21) and (16) respectively.
- Remove remaining screws (21).
- Remove dowel pins from bearing housing.

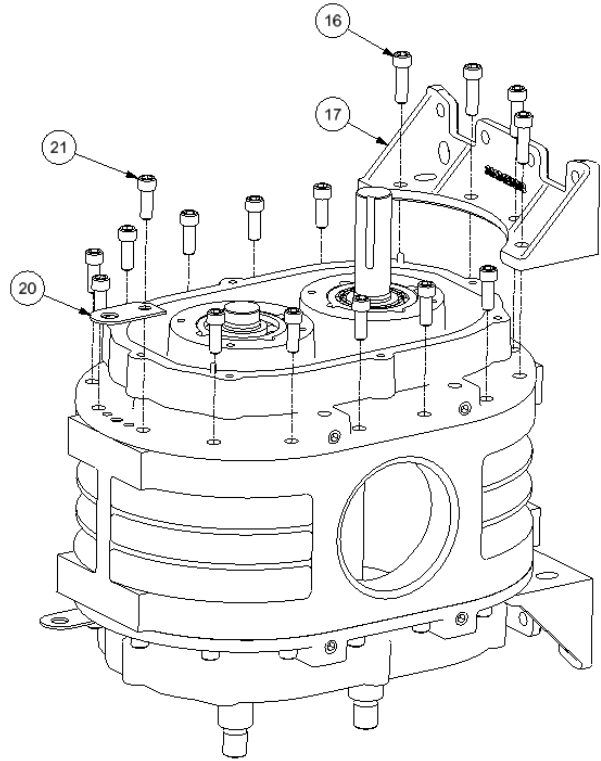

7- 9 – Puller Plate Installation

- Install puller plate (J) as shown.

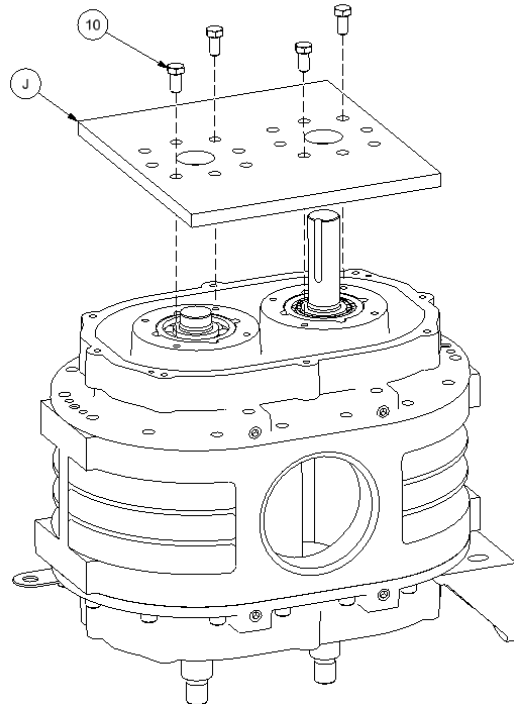

7- 10 – Bearing Housing Removal

- Install gear pullers as shown.
- Tighten each puller to extract bearing housing.
- NOTE – Keep each shaft advancing evenly by switching back and forth only rotating each puller $\frac{1}{2}$ turn.
- Using a hammer and punch, remove oil seals from bearing housing.
- NOTE – Seals and bearings should be replaced during overhaul. Bearings are a “slip fit” in housing and should be removed by hand.
- Rotate unit 180° so gear end is up.
- Repeat steps in 5-6, 5-7, and 5-8 to remove gear end bearing housing.

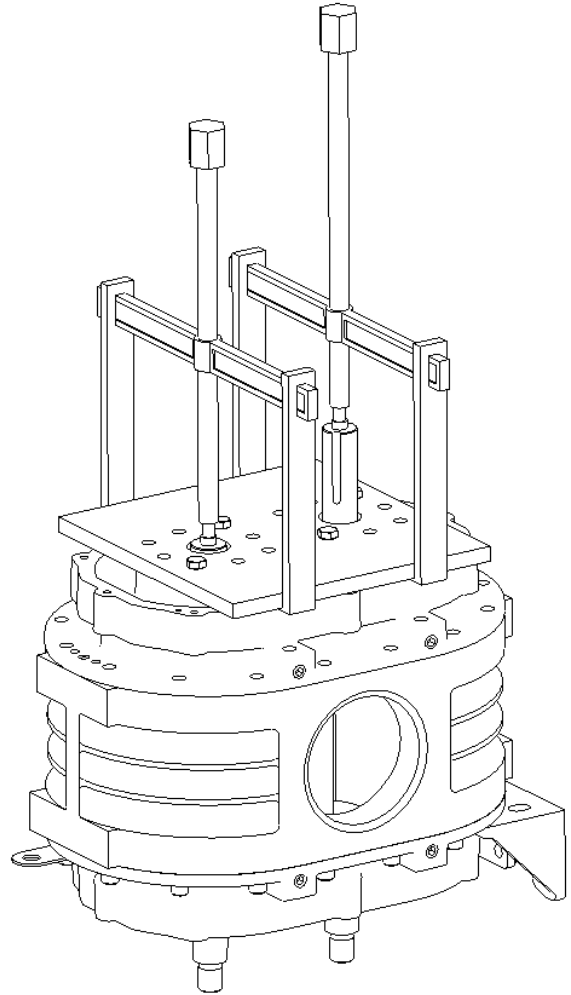

7-11 – Bearing Housing Installation

- **NOTE** – Before installing drive end bearing housing, use a depth micrometer to measure expansion clearance between rotors and machined cylinder face. Paper shims may be required to achieve proper clearance.

Expansion End Clearance	0.009”-0.014”
-------------------------	---------------

- Using a hammer, install dowel pins (19) into cylinder.
- Mount bearing housing on cylinder ensuring dowel pins are aligned.
- Install lifting lug (20) and screws (21).
- Install mounting (17) and screws (16).
- Tighten screws.

Screw, bearing housing	3/8-16 UNC	30 lb-ft
------------------------	------------	----------

- **NOTE** – Vertical bottom shaft drive dual splash lubrication configuration shown.

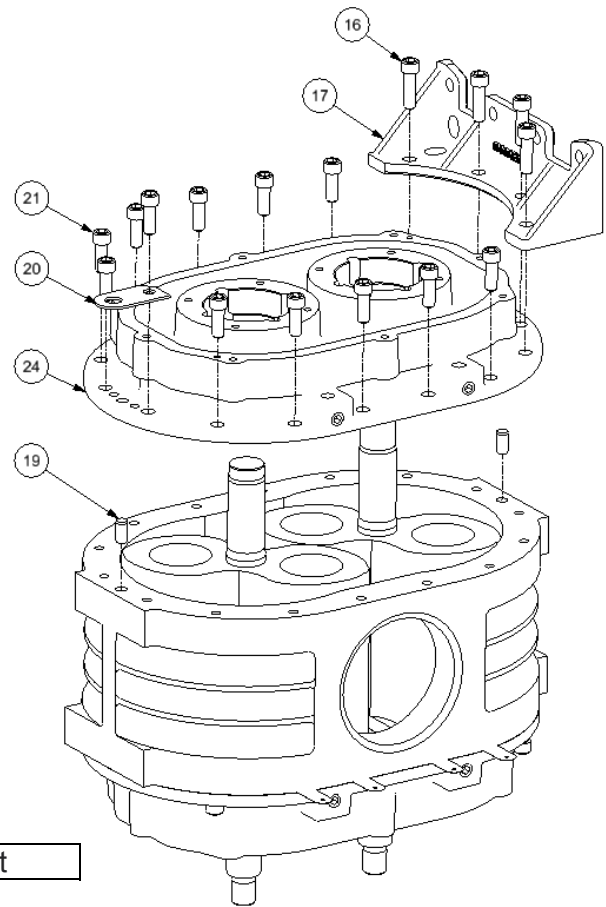

7-12 – Bearing Installation, Drive End (lip seal)

- Using a press and bearing driver tool (C), install drive end bearings (80) and (35).
- Rotate unit 180° so gear end shafts are up in a vertical orientation.

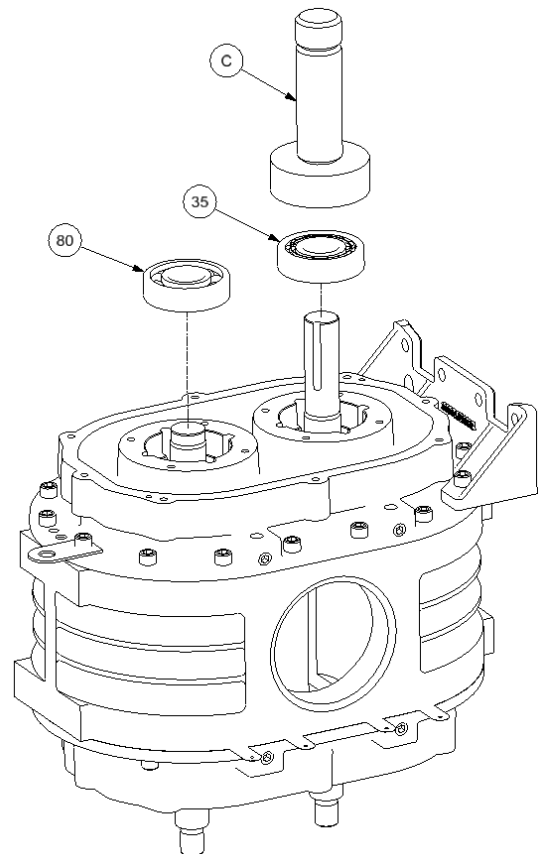

7-13 – Bearing Installation, Drive End (lip seal)

- Carefully place mechanical seal rotating ring (15) over shaft and against carbon face.
- Using a press and bearing driver tool (C), install drive end bearings (80) and (35).
- Rotate unit 180° so gear end shafts are up in a vertical orientation.

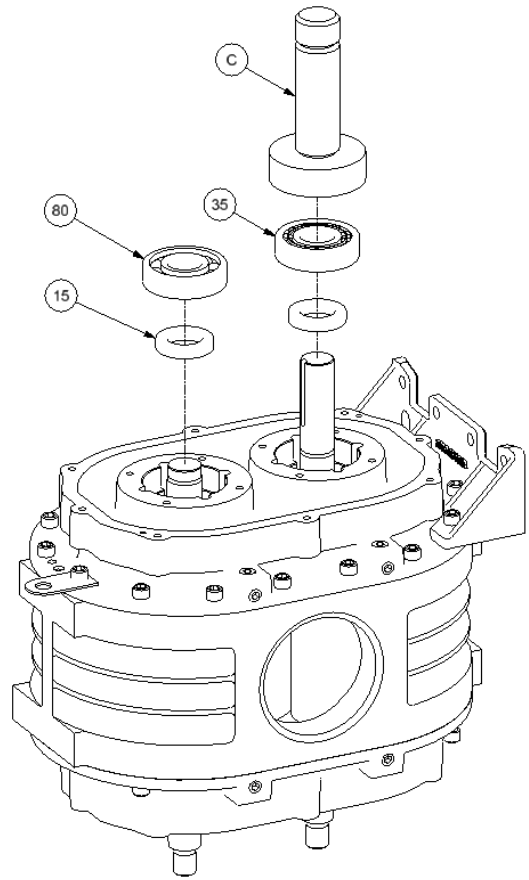

7-14 – Bearing Installation, Gear End

- **NOTE** – For mechanical seal units, install rotating ring (15) over shaft and against carbon face as shown in step 7-5 before installing bearings.
- Using driver (D), hollow hydraulic ram (E), and pull rod assembly (F), install gear end bearings (14).
- **NOTE** – Do not exceed 10,100 psi press pressure.
- **NOTE** – One end of driver (D) is used to install bearings and the other end is used to install gears. One end has a slight recess for bearing installation and the other end is without a recess for gear installation. Failure to orient accordingly will result in extreme difficulty removing end clearance shims.

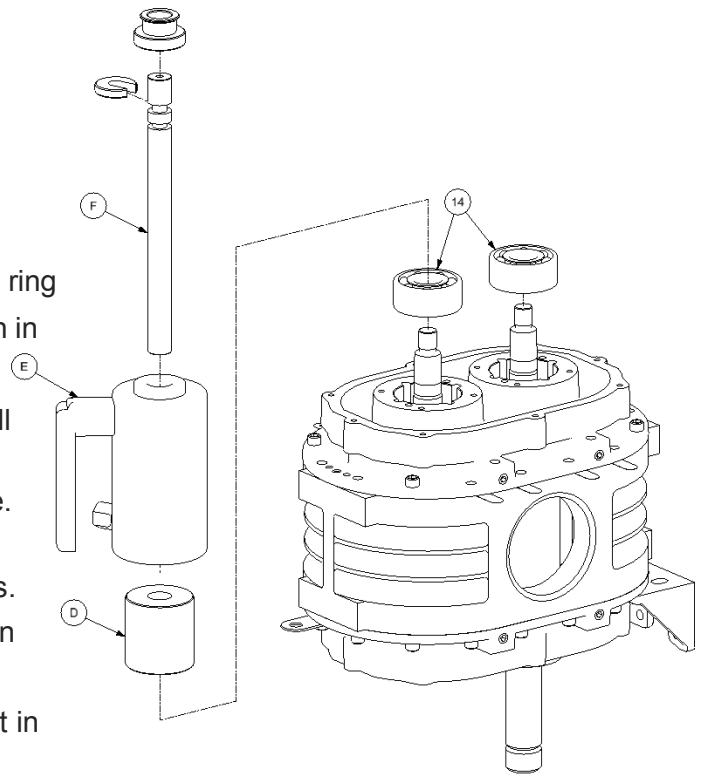

7-15 – Bearing Retention

- Install washers (12) and screws (10).
- Tighten screws.

Screw, bearing retention	3/8-16 UNC	30 lb-ft
--------------------------	------------	----------

- Loosen and/or remove screws (21).
- Utilizing feeler gauge puller (G), remove feeler gauges.
- **NOTE** – Pliers or a hook tool may be required to remove feeler gauges if feeler gauge puller (G) is not being utilized.

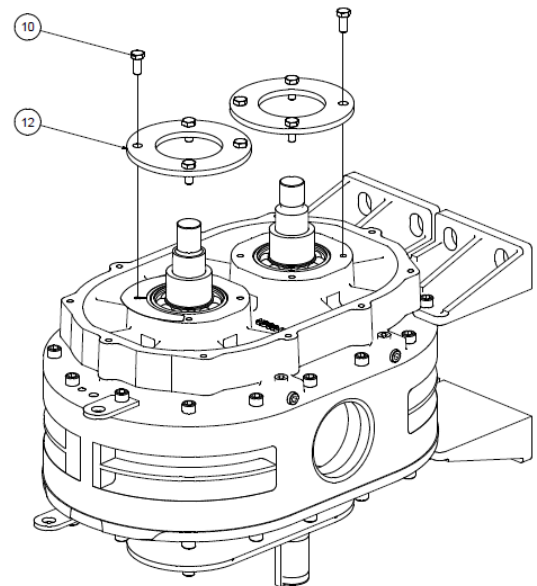

7-16 – Mounting Foot Installation

- Install lifting lug (20) and mounting foot (17) using screws (21) and (16) respectively.
- Secure bearing housing to cylinder using screws (21).
- Tighten screws.

Screw, bearing housing	3/8-16 UNC	30 lb-ft
------------------------	------------	----------

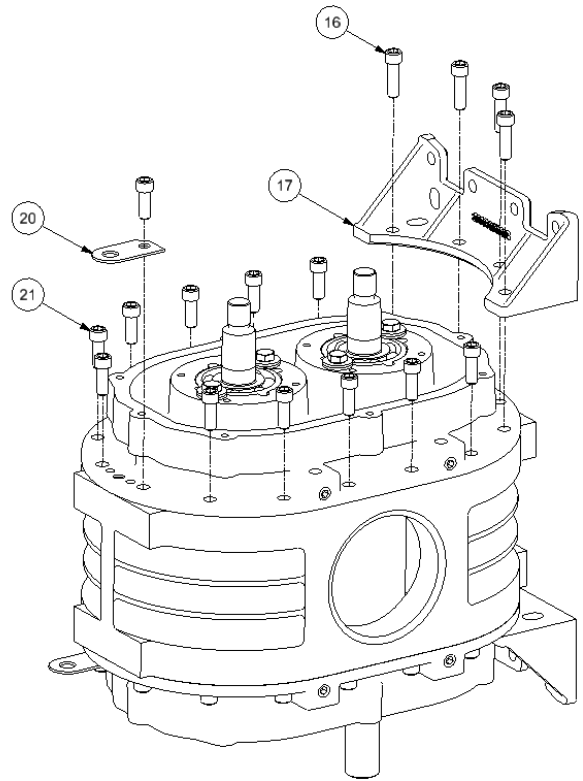

7-17 – Setting Interlobe Clearance

- Using the table below, assemble rotor locking device (F) with proper feeler gauge.

6" All	Center Timed	0.012"
--------	--------------	--------

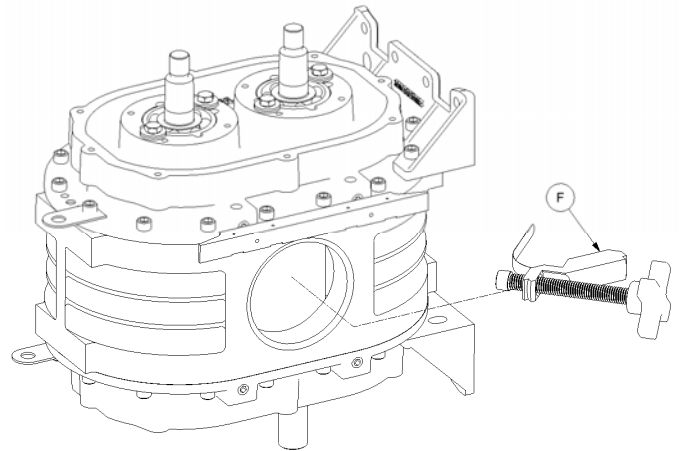

- Position rotor locking device in inlet port while positioning feeler gauge in between the rotors as shown.
- Tighten adjusting knob until locked firmly against impeller body.

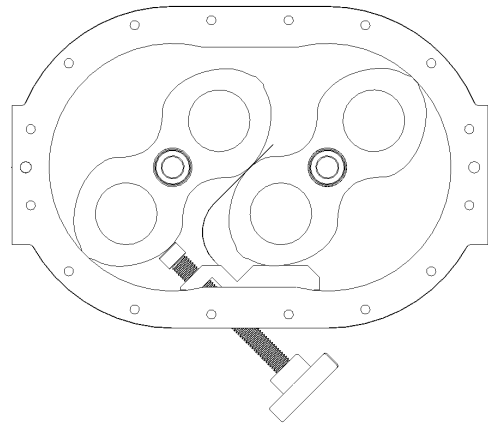

7-18 – Gear Installation (idler gear)

- Place a gear (39) on idler shaft and install pull rod (E) on shaft.
- Position driver (E) over pull rod so top of driver is even with lower groove.
- Release driver allowing it to freely drop on the gear, seating gear on shaft.
- Remove driver.
- Using a depth micrometer, measure dimension A ensuring minimum is achieved.

6"	0.090"min
----	-----------

- Place driver (E), hydraulic ram (D) over pull rod (E).
- Install retaining washer (E) in upper groove and slide safety cap (E) over shaft and washer to secure.
- Apply hydraulic pressure to ram to press gear into place.
- NOTE – Driver (E) is designed to not travel beyond shoulder on shaft, allowing gear face to be flush with shoulder. Do not exceed 15,000 lbs of press force or damage may occur to shaft.

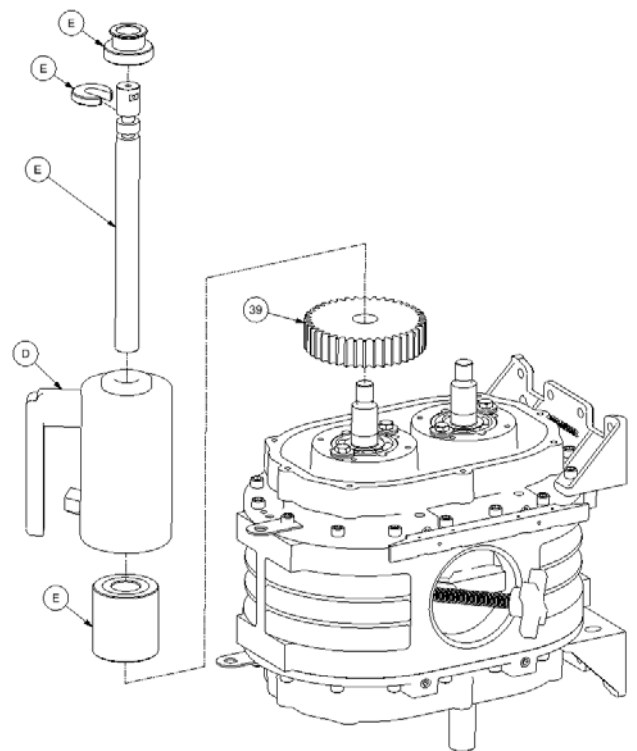
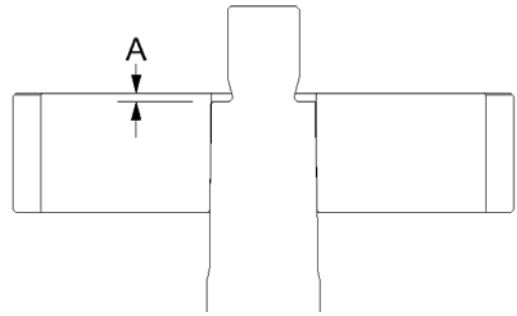

7-19 – Gear Installation (drive gear)

- Place a gear (39) on drive shaft and install pull rod (E).
- Position driver (E) over pull rod so top of driver is even with lower groove.
- Rotate and hold gear in mesh against other gear in direction of operational rotation to remove backlash.
- Release driver allowing it to freely drop on the gear, seating gear on shaft.
- Remove driver.
-
- Using a depth micrometer, measure dimension A ensuring minimum is achieved.

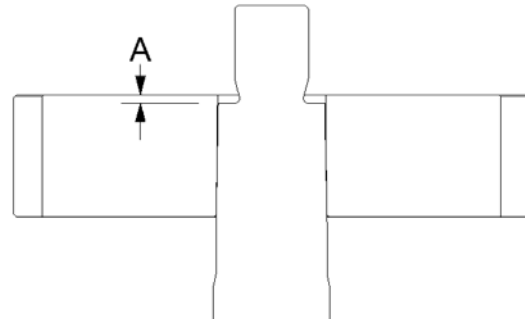

NOTE: If min dimension is not achieved, gear and/or shaft may need replaced.

6"	0.090"min
----	-----------

- Place driver (E), hydraulic ram (D) on pull rod (E) as shown.
- Install retaining washer (E) on upper groove and slide safety cap (E) over washer to secure.
- Apply hydraulic pressure to ram to press gear into place.
- NOTE – Driver (E) is designed to not travel beyond shoulder on shaft, allowing gear face to be flush with shoulder. Do not exceed 15,000 lbs of press force or damage may occur to shaft.

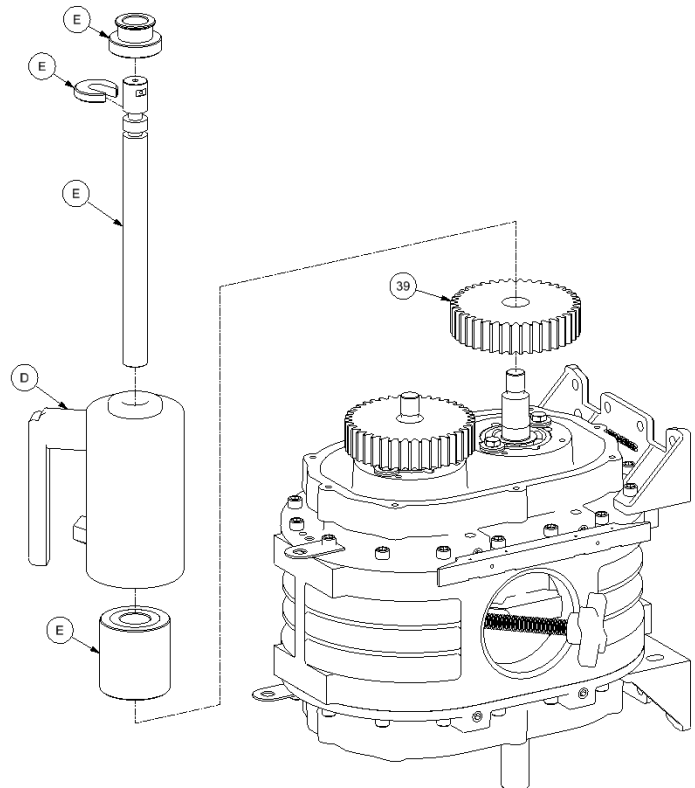

7-20 – Flange Nut Installation

- Apply Loctite 243 to threads of flange nut (41) and install on each shaft.
- Tighten nuts.

6"	Nut, shaft	1-14	60 lb-ft
----	------------	------	----------

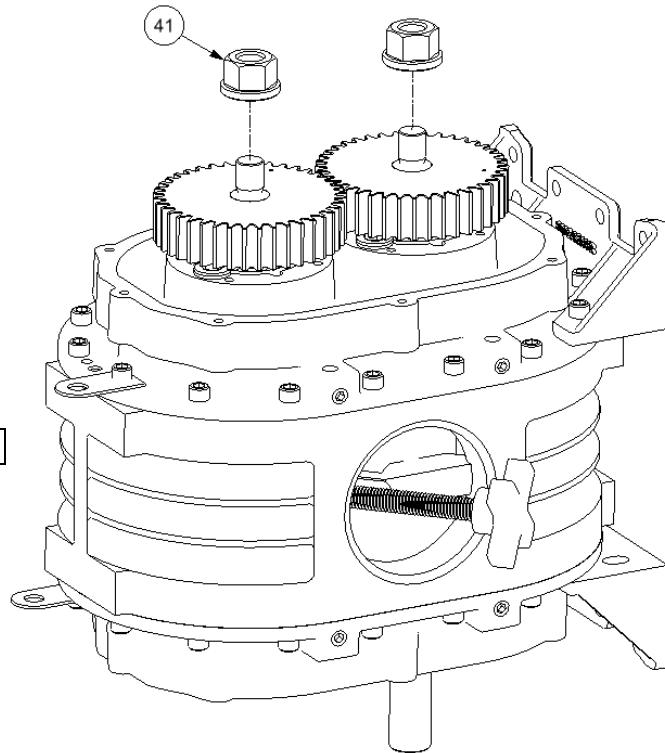

7-21 – Gear Cover Installation

- Install O-ring (7) into gear cover (3).
- Secure sump cover to bearing housing using screws (30).
- Tighten screws.

Screw, gear cover	5/16-18 UNC	156 lb-in
-------------------	-------------	-----------

- Apply thread sealant to plugs (2), oil level gauge (40) and breather (6) and install according to unit configuration.
- Tighten plugs, gauge, and breather.

Plugs, gauge, breather	1/2 NPT
------------------------	---------

- Rotate unit 180° so drive end is facing up.

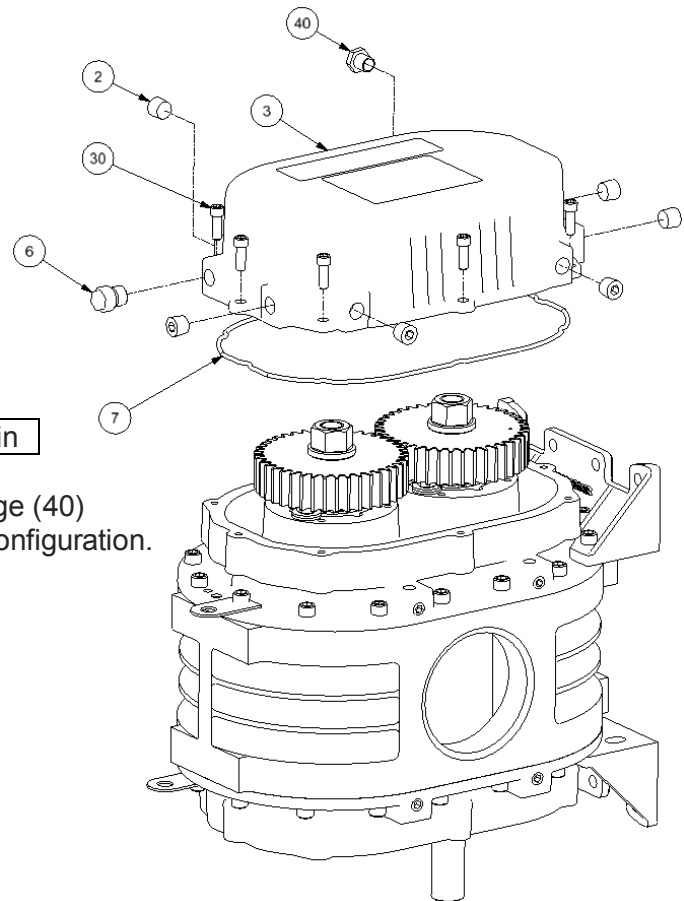

7- 22 – Seal Installation (lip seals)

- Ensure bearing housings are clean and free of any nicks and burrs.
- Apply grease or light oil to the inner and outer diameter of each shaft seal (15) .
- Using a press and seal driver (A) , carefully install each seal until fully seated.
- Apply thread sealant to plugs (44).
- Tighten plugs.

6"	Plug, air vent	1/2-13 UNC
----	----------------	------------

- Repeat steps for other bearing housing.

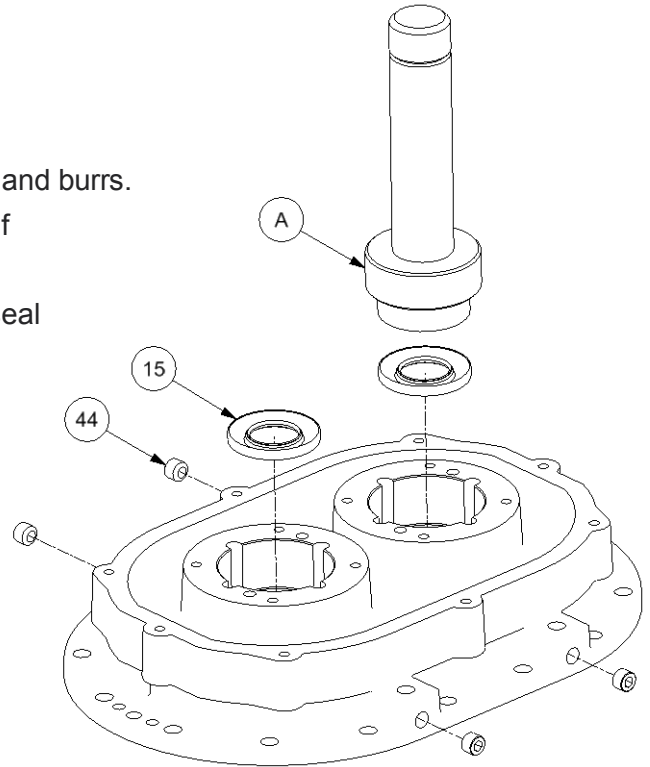

7-23 – Seal Installation (mechanical seals)

- Ensure bearing housings are clean and free of any nicks and burrs.
- Apply assembly lubricant to each seal bore.
- Using a press and seal driver (B), carefully install each seal (cup and carbon assembly only) until fully seated.
- **NOTE** – Use extreme care when handling or installing mechanical seals. Blows from a hammer can damage the fragile seal surface. Too much force can crush the seal casing. Ensure seal is fully seated and undamaged before proceeding.
- Apply thread sealant to plugs (44) and (46).
- Tighten plugs.

6"	Plug, air vent	1/2-13 UNC
----	----------------	------------

- Repeat steps for the other bearing housing

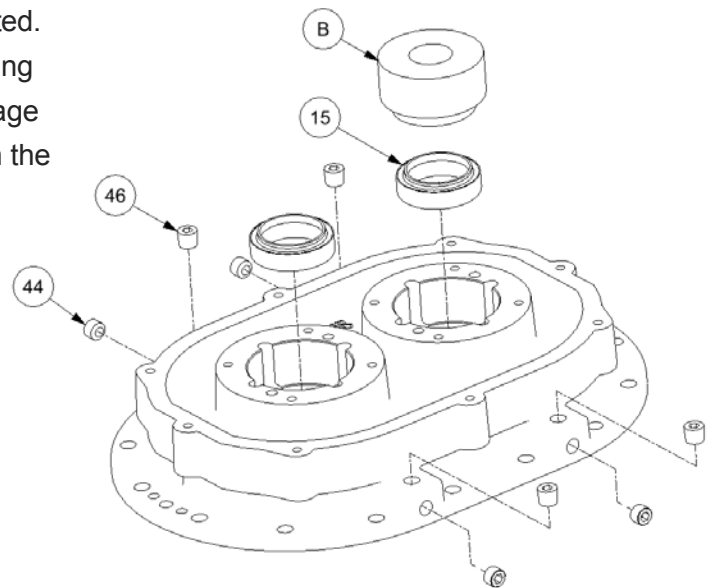

7-24 – Slinger Installation

- Assemble slingers (83) to shafts using screws (84).
- Tighten screws.

Screw, slinger	8-32 UNC	18 lb-in
----------------	----------	----------

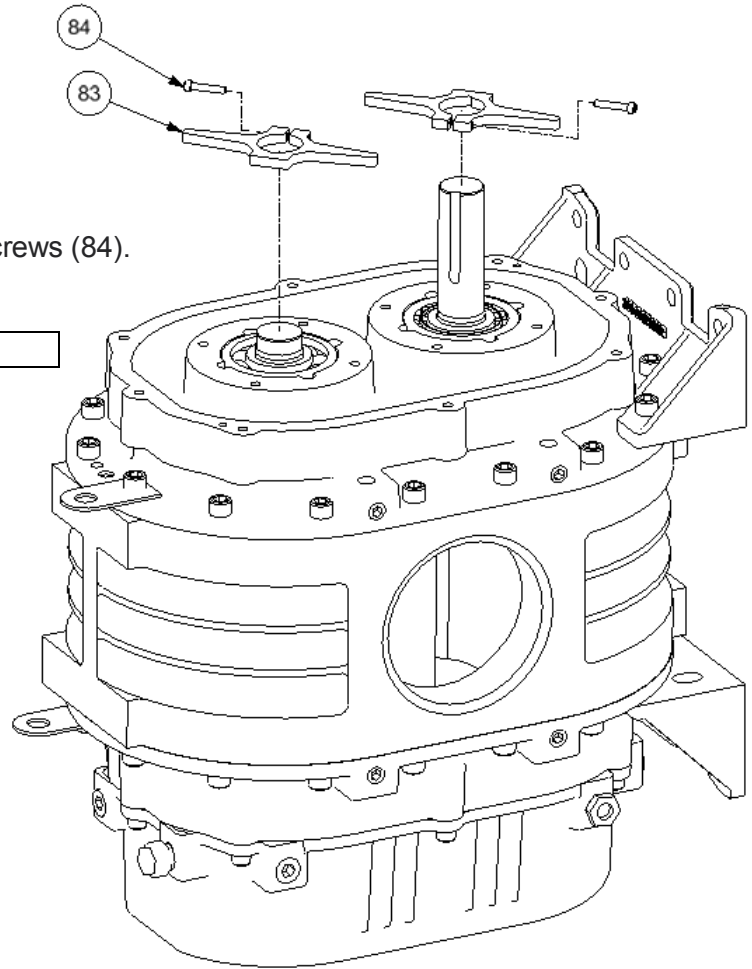

7-25 – Drive Shaft Seal Installation

- While supporting cover from underside
With a block of wood, use a hammer,
to carefully install oil seal (31) into
drive cover (29) from front.
- **NOTE** – Seal face should be flush
with drive cover face.

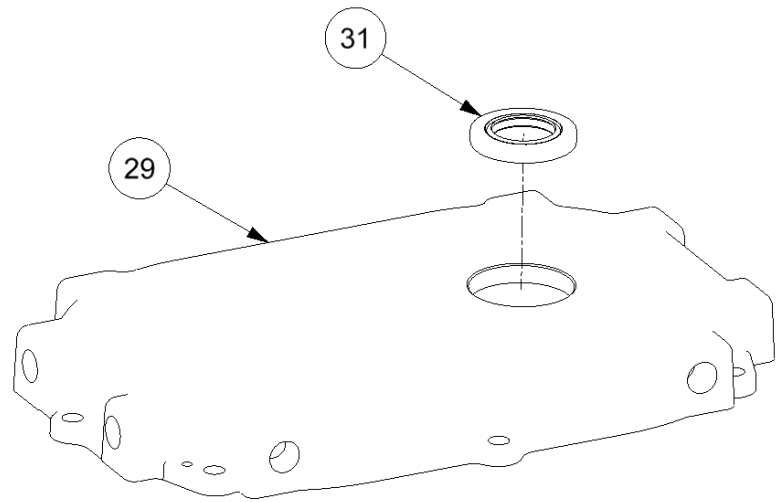

7-26 – Drive Cover Installation

- Using a hammer, install dowel pins (81).
- Install O-ring (7) into drive cover (29).
- Secure drive cover (29) to bearing housing using screws (30).

Screw, drive cover	5/16-18 UNC	156 lb-in
--------------------	-------------	-----------

- Apply thread sealant to plugs (2), oil level gauge (40) and breather (6) and install according to unit configuration.
- Tighten plugs, gauge, and breather.

Plugs, gauge, breather	1/2 NPT
------------------------	---------

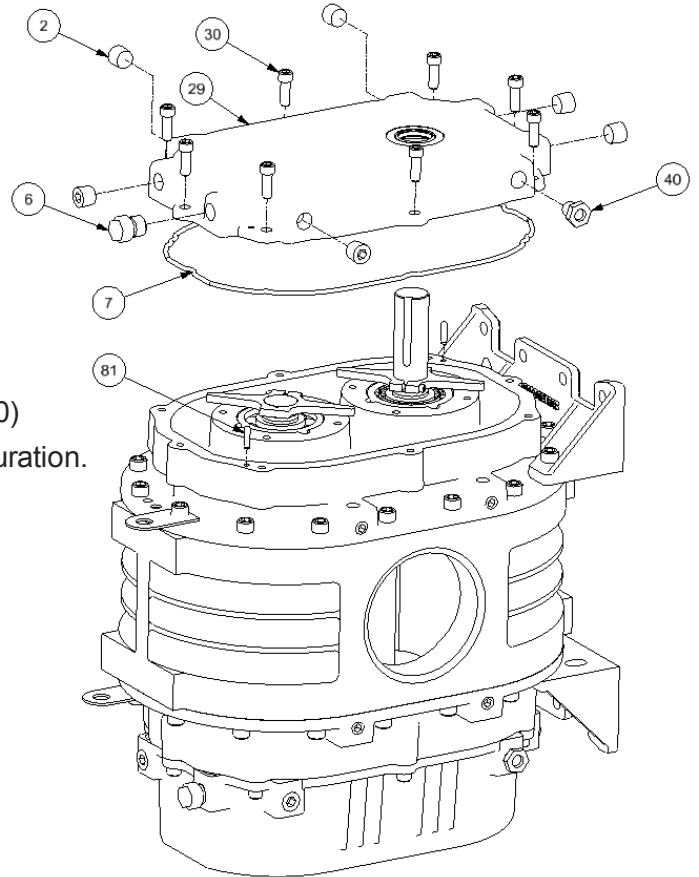

7-27 – Cylinder Installation

- Using a hammer, install dowel pins 19 into gear end bearing housing 18.
- Position four feeler gauges on bearing housing as shown.

Feeler Gauge	0.004"
--------------	--------

- **NOTE** – Feeler gauges are used to set the rotor end clearance. Ensure enough of the gauge is extended and accessible for removal.
- Mount cylinder 22 ensuring dowel pins are aligned.
- Install four screws 21 to temporarily secure cylinder to bearing housing.
- Tighten screws.

Screw, cylinder	3/8-16 UNC	30 lb-ft
-----------------	------------	----------

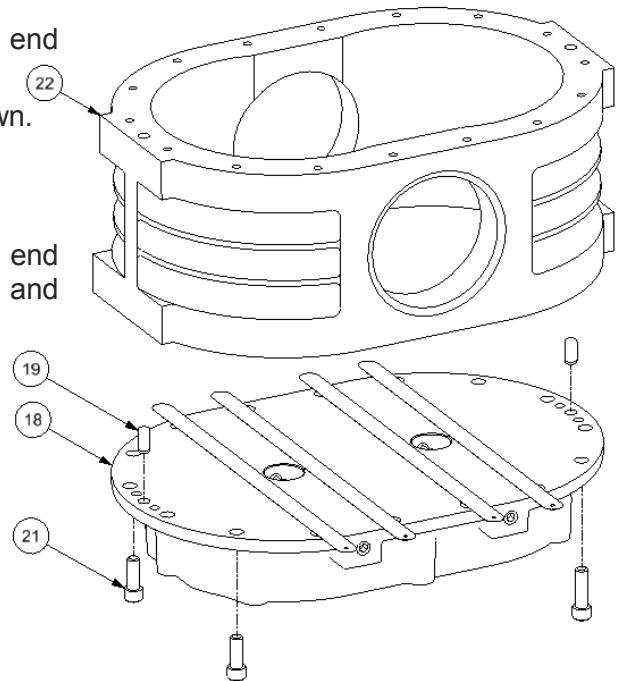

7-28 – Rotor Installation

- Insert rotors (23) into cylinder as shown.
- **NOTE** – Use caution when installing rotors as misalignment can cause shaft to damage seals.
- **NOTE** – For 'Q' cylinder models, ensure drive rotor position and rotation match configuration. Failure to do so will result in greatly reduced performance.

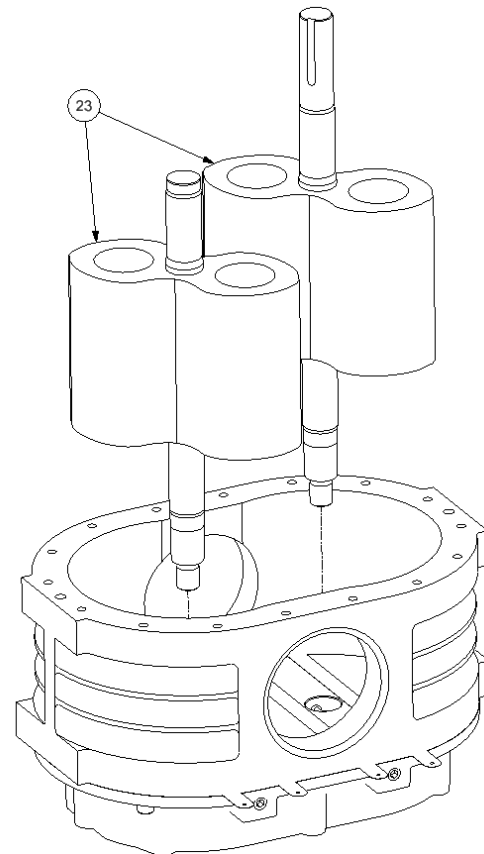

SECTION 8 DISASSEMBLY INSTRUCTIONS

NOTICE

Numbers in parentheses () refer to key numbers in assembly drawings on pages 39 and 43.

1. Drain oil from gear case by removing drain plug (2).
2. Remove the socket head bolts (5) from the gear cover (3).
3. Remove the gear cover from the gear headplate.

IMPORTANT:

MARK ALL PARTS WITH A CENTER PUNCH SO THEY CAN BE REASSEMBLED IN THE SAME POSITION (IMPELLERS, HEADPLATES, AND GEARS).

4. If the timing gears appear undamaged, the gear backlash must be checked to see if the gears can be salvaged.
 - A. Mount a magnetic base dial indicator on the gear headplate (see FIGURE 6-1).
 - B. Lock one impeller stationary by wedging a feeler gauge between the impeller and the headplate.
 - C. The tip of the indicator should be placed at the center of the contact surface on a tooth of the gear on the free shaft.
 - D. Rock the impeller back and forth by hand and read the total rotational movement to the nearest .0005 inches. Do this at four gear mesh positions 90 degrees apart.
 - E. Permissible gear backlash is shown below.

GEAR DIA.	GEAR BACKLASH
6"	.002 - .003



FIGURE 8-1

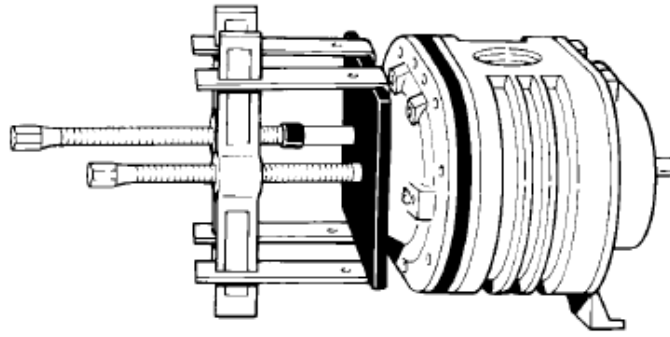

FIGURE 8- 2

NOTICE

If backlash is above the specified limit, the gears are not necessarily unusable. Excessive play could be caused by worn bearings.

5. If timing gears appear to be reusable, match mark timing gear toothmesh by making small punch marks on the ends of meshing gear teeth with a pin punch and hammer. The impeller tip to valley (throat) and the case to headplates should also be matchmarked to facilitate blower reassembly.

NOTICE

Blowers with mechanical seals have two wavy washers (28) located between the bearings and the cover on the drive end of grease version or between the bearings and the wavy spring retainer plate on dual splash version.

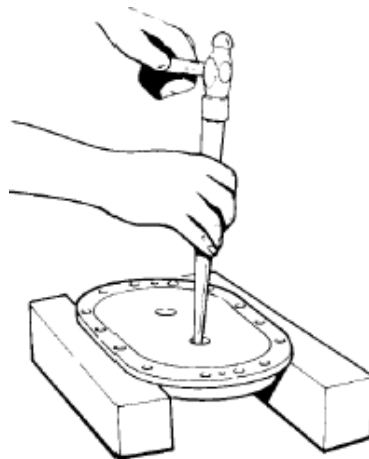
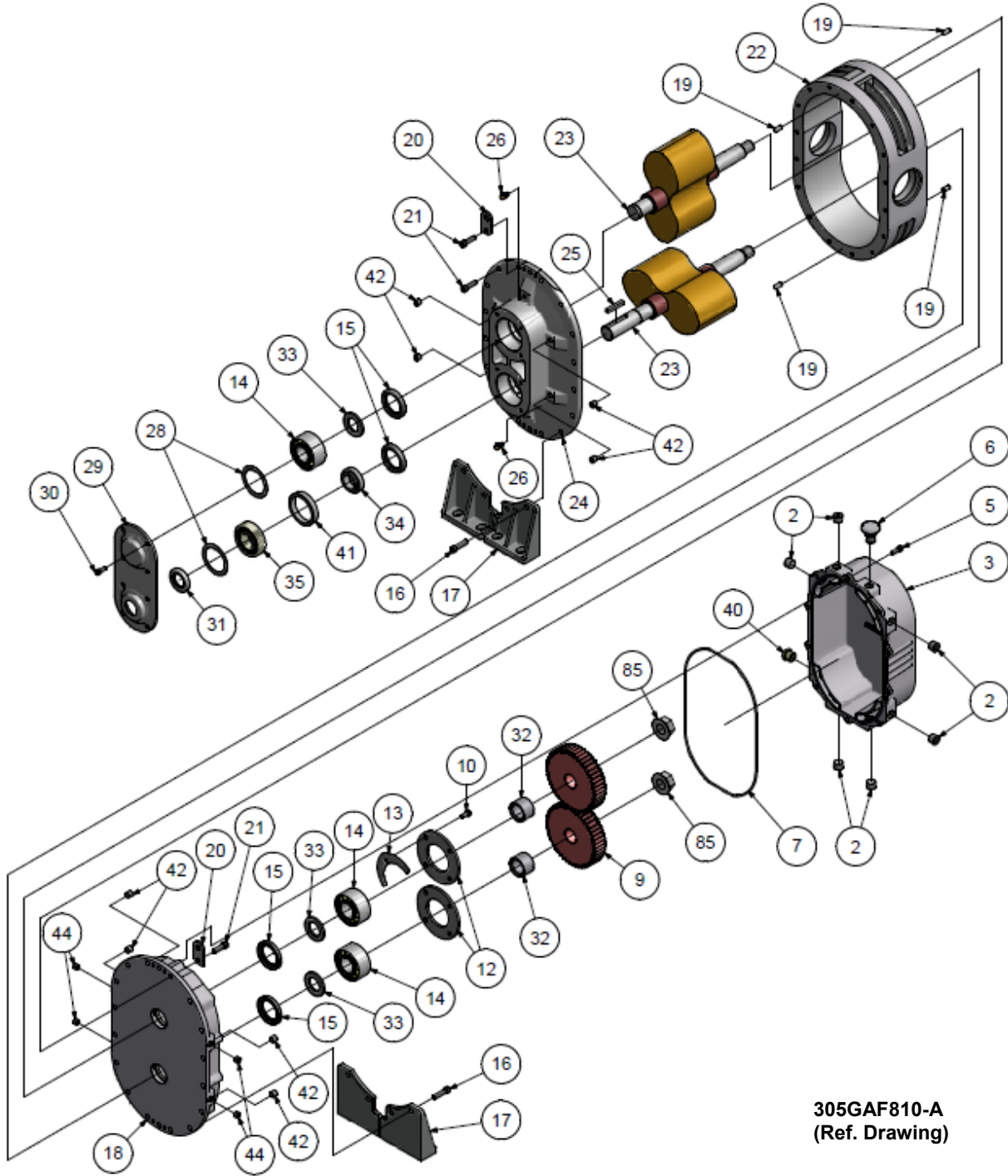

FIGURE 8- 3

**SECTION 9
PARTS LIST**



**305GAF810-A
(Ref. Drawing)**

Order by Part Number and Description. Reference Numbers are for your convenience only.

Ref. No.	Model GAF Description	Lip Seal No. Req'	Grease Splash Lube		
			Size – 6H GAFH_S Δ	Size – 6M GAFM_S Δ	Size -- 6L GAFL_S Δ
2	PLUG	6	64AC4	64AC4	64AC4
3	GEAR CASE	1	303GAF602	303GAF602	303GAF602
5	SCREW	10	75P40	75P40	75P40
6	BREATHER.....	1	5L223	5L223	5L223
* 7	O-RING	1	TEN010748	TEN010748	TEN010748
9	GEAR KIT	1	302GAF6008	302GAF6008	302GAF6008
*10	SCREW.....	8	75A33P	75A33P	75A33P
12	BEARING RETAINER.....	2	900883065501	900883065501	900883065501
*13	SHIM SET	1	900881065400	900881065400	900881065400
13	THRUST SHIM .020"	4	900881065408	900881065408	900881065408
*14	MAIN BEARING	3	900639080506	900639080506	900639080506
*15	OIL SEAL	4	60DD657	60DD657	60DD657
16	SCREW.....	8	75P57	75P57	75P57
17	FOOT GROUP.....	1	306GAF166	306GAF166	306GAF166
18	HOUSING, GEAR END BEARING.....	1	302GAF006	302GAF006	302GAF006
19	DOWEL PIN	4	62M48	62M48	62M48
20	LUG.....	2	201GAF451	201GAF451	201GAF451
21	SCREW.....	24	75P56	75P56	75P56
22	CYLINDER.....	1	900883063901	900883064001	900883064101
23	ROTOR GROUP				
	6" Standard Clearance.....	1	318GAF4028	319GAF4028	320GAF4028
	6" High Temperature Clearance.....	1	TO BE ASSIGNED	TO BE ASSIGNED	TO BE ASSIGNED
24	HOUSING, DRIVE END BEARING	1	900883064901	900883064901	900883064901
25	SQUARE KEY	1	900639910406	900639910406	900639910406
26	PIPE FITTING	2	40E9	40E9	40E9
27	CAP.....	2	40P58	40P58	40P58
*28	WAVY SPRING.....	2	900669170506	900669170506	900669170506
29	DRIVE COVER	1	900883064601	900883064601	900883064601
30	SCREW	8	75P189	75P189	75P189
*31	OIL SEAL	1	60DD658	60DD658	60DD658
32	SPACER	2	300GAF144	300GAF144	300GAF144
33	SEAL SPACER	3	900881066201	900881066201	900881066201
34	SPACER	1	900881066401	900881066401	900881066401
*35	BEARING	1	900811060801	900811060801	900811060801
40	OIL LEVEL GAUGE	1	40P31	40P31	40P31
44	SCREW.....	4	76F92	76F92	76F92
45	PAINT, BULK, GDP188, ALUM.....	0.125	28H284	28H284	28H284
*54	SHIM .003".....	1	200GAF732	200GAF732	200GAF732
55	SHIM .010".....	1	201GAF732	201GAF732	201GAF732
*56	SHIM .0015/.002".....	1	202GAF732	202GAF732	202GAF732
83	NUT.....	2	TST000179	TST000179	TST000179
Δ **105	KIT – OVERHAUL 6" R&S VERS LS GRS-SPL..	1	305GAF6010	305GAF6010	305GAF6010
**900	GRP – IDENT & INSTRUCTION.....	1	202GAF4011	202GAF4011	202GAF4011

* INCLUDED IN OVERHAUL KIT.

** NOT SHOWN ON ILLUSTRATION.

Δ OVERHAUL KITS WILL HAVE EXTRA O-RINGS OR GASKETS. THIS DEPENDS ON MODEL NUMBER.

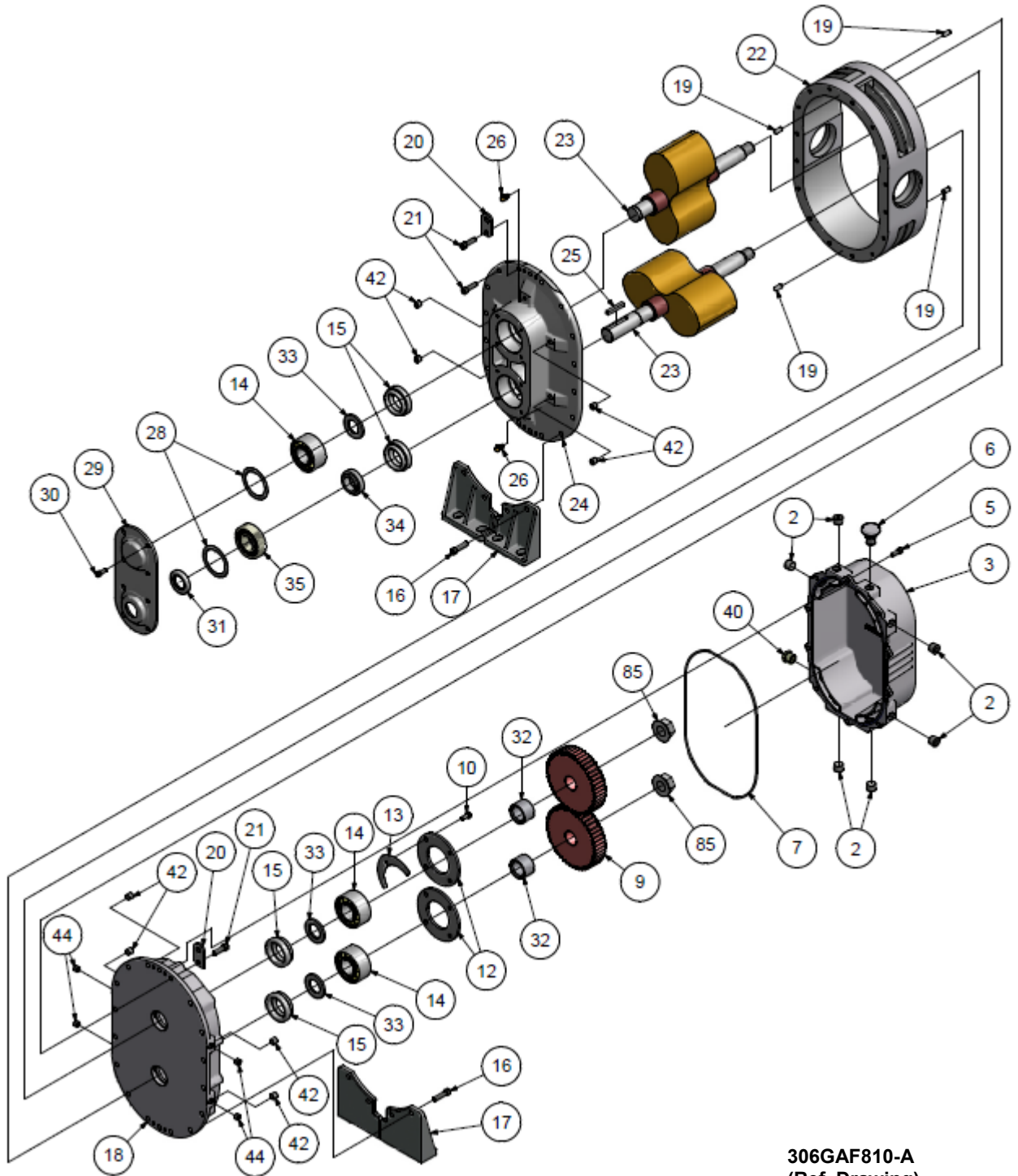

306GAF810-A
 (Ref. Drawing)

Order by Part Number and Description. Reference Numbers are for your convenience only.

Ref. No.	Model GAF Description	Mechanical Seal	Grease Splash Lube			
			No. Req ¹	Size – 6H GAFH_SB	Size – 6M GAFM_SB	Size -- 6L GAFL_SB
2	PLUG		6	64AC4	64AC4	64AC4
3	GEAR CASE		1	303GAF602	303GAF602	303GAF602
5	SCREW		10	75P40	75P40	75P40
6	BREATHER		1	5L223	5L223	5L223
*7	O-RING		1	TEN010748	TEN010748	TEN010748
9	GEAR KIT		1	302GAF6008	302GAF6008	302GAF6008
*10	SCREW		8	75A33P	75A33P	75A33P
12	BEARING RETAINER		2	900883065501	900883065501	900883065501
13	THRUST SHIM .020"		4	900881065408	900881065408	900881065408
*13	SHIM SET		1	900881065400	900881065400	900881065400
*14	MAIN BEARING		3	900639080506	900639080506	900639080506
*15	MECHANICAL SEAL		4	900871020006	900871020006	900871020006
16	SCREW		8	75P57	75P57	75P57
17	FOOT GROUP		1	306GAF166	306GAF166	306GAF166
18	HOUSING-BEARING GEAR END		1	304GAF006	304GAF006	304GAF006
19	DOWEL PIN		4	62M48	62M48	62M48
20	LUG		2	201GAF451	201GAF451	201GAF451
21	SCREW		24	75P56	75P56	75P56
22	CYLINDER		1	900883063901	900883064001	900883064101
23	ROTOR		1	318GAF4028	319GAF4028	320GAF4028
24	HOUSING-BEARING DRIVE END		1	305GAF006	305GAF006	305GAF006
25	SQUARE KEY		1	900639910406	900639910406	900639910406
26	PIPE FITTING		2	40E9	40E9	40E9
27	CAP		2	40P58	40P58	40P58
*28	WAVY SPRING		2	900669170506	900669170506	900669170506
29	DRIVE COVER		1	900883064601	900883064601	900883064601
30	SCREW		8	75P189	75P189	75P189
*31	OILSEAL		1	60DD658	60DD658	60DD658
32	SPACER		2	300GAF144	300GAF144	300GAF144
33	SEAL SPACER		3	900881066201	900881066201	900881066201
34	SPACER		1	900881066401	900881066401	900881066401
*35	BEARING		1	900811060801	900811060801	900811060801
40	OIL LEVEL GAUGE		1	40P31	40P31	40P31
41	SPACER-DRIVE END		1	900881066301	900881066301	900881066301
42	PLUG		8	64AC2	64AC2	64AC2
44	SCREW		4	76F92	76F92	76F92
45	PAINT, BULK GDP188, ALUM		1	28H284	28H284	28H284
53	PLUG		2	8503064	64EB750	200GDF6015
*54	SHIM .003"		1	200GAF732	200GAF732	200GAF732
55	SHIM .0010"		1	201GAF732	201GAF732	201GAF732
*56	SHIM .0015/.002"		1	202GAF732	202GAF732	202GAF732
83	NUT		2	TST000179	TST000179	TST000179
Δ**105	KIT-OVERHAUL 6" R&S VERSION MS GRS-SPL		1	306GAF6010	306GAF6010	306GAF6010
**900	GRP-IDENT & INSTR		1	202GAF4011	202GAF4011	202GAF4011

* INCLUDED IN OVERHAUL KIT

** NOT SHOWN ON ILLUSTRATION

Δ OVERHAUL KITS WILL HAVE EXTRA O-RINGS OR GASKETS. THIS DEPENDS ON MODEL NUMBER.

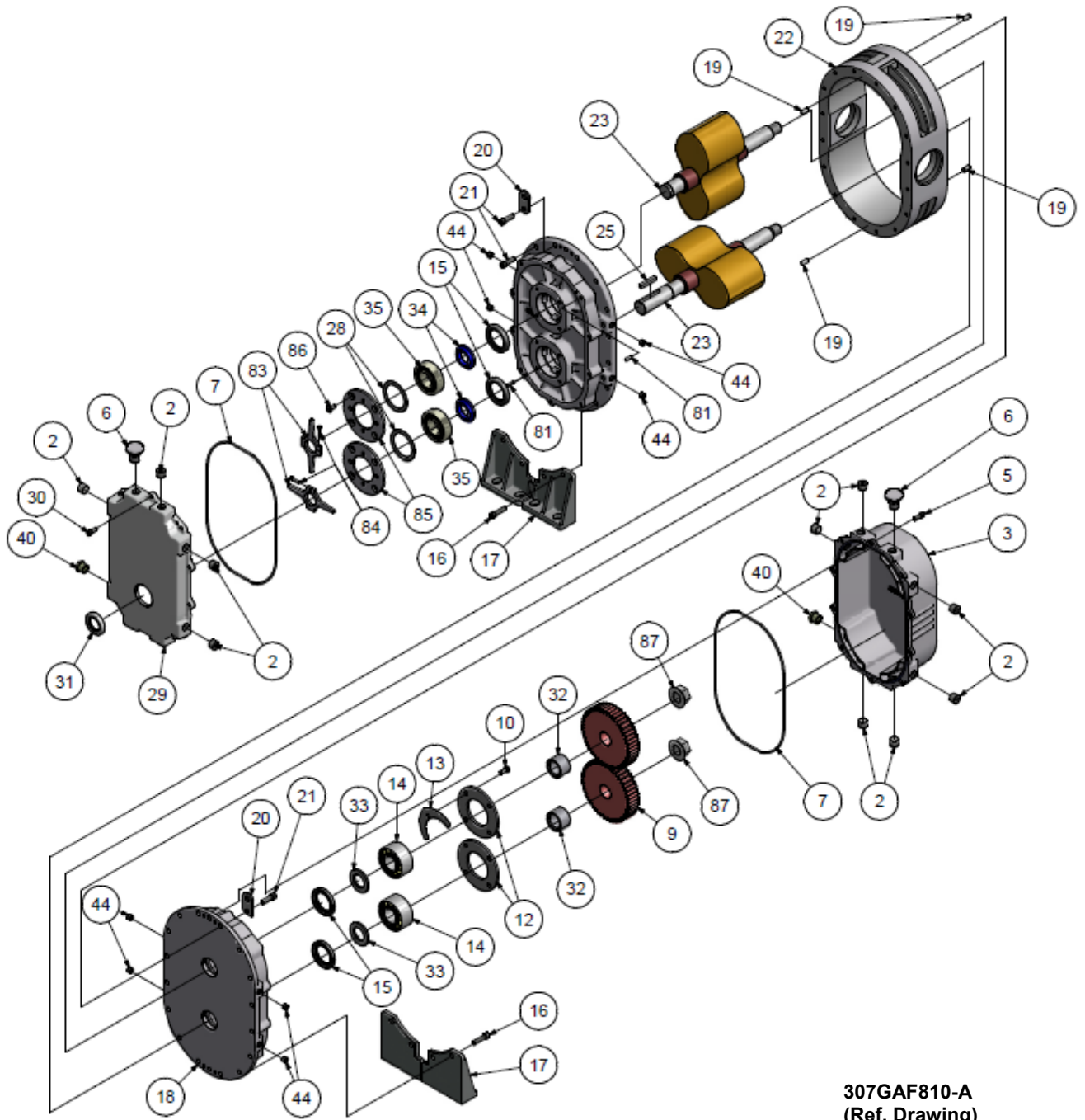

307GAF810-A
(Ref. Drawing)

Order by Part Number and Description. Reference Numbers are for your convenience only.

Ref. No.	Model GAF Description	Lip Seal No. Req'	Dual Splash Lube		
			Size – 6H GAFH_S Δ	Size – 6M GAFM_S Δ	Size -- 6L GAF6L_S Δ
2	PLUG.....	12	64AC4	64AC4	64AC4
3	GEAR CASE.....	1	303GAF602	303GAF602	303GAF602
5	SCREW.....	10	75P40	75P40	75P40
6	BREATHER.....	2	5L223	5L223	5L223
* 7	O-RING.....	2	TEN010748	TEN010748	TEN010748
9	GEAR KIT.....	1	302GAF6008	302GAF6008	302GAF6008
*10	SCREW.....	8	75A33P	75A33P	75A33P
12	BEARING RETAINER.....	2	900883065501	900883065501	900883065501
*13	SHIM SET.....	1	900881065400	900881065400	900881065400
13	THRUST SHIM .020".....	4	900881065408	900881065408	900881065408
*14	MAIN BEARING.....	2	900639080506	900639080506	900639080506
*15	OIL SEAL.....	4	60DD657	60DD657	60DD657
16	SCREW.....	8	75P57	75P57	75P57
17	FOOT GROUP.....	1	306GAF166	306GAF166	306GAF166
18	HOUSING, GEAR END BEARING.....	1	302GAF006	302GAF006	302GAF006
19	DOWEL PIN.....	4	62M48	62M48	62M48
20	LUG.....	2	201GAF451	201GAF451	201GAF451
21	SCREW.....	24	75P56	75P56	75P56
22	CYLINDER.....	1	900883063901	900883064001	900883064101
23	ROTOR GROUP				
	6" Standard Clearance.....	1	318GAF4028	319GAF4028	320GAF4028
	6" High Temperature Clearance.....	1	TO BE ASSIGNED	TO BE ASSIGNED	TO BE ASSIGNED
24	HOUSING, DRIVE END BEARING.....	1	303GAF006	303GAF006	303GAF006
25	SQUARE KEY.....	1	900639910406	900639910406	900639910406
*28	WAVY SPRING.....	2	900669170506	900669170506	900669170506
29	DRIVE COVER.....	1	302GAF477	302GAF477	302GAF477
30	SCREW.....	10	75P40	75P40	75P40
*31	OIL SEAL.....	1	60DD658	60DD658	60DD658
32	SPACER.....	2	300GAF144	300GAF144	300GAF144
33	SPACER.....	2	900881066201	900881066201	900881066201
34	SPACER.....	2	301GAF144	301GAF144	301GAF144
*35	BEARING.....	2	900811060801	900811060801	900811060801
40	OIL LEVEL GAUGE.....	2	40P31	40P31	40P31
44	SCREW.....	8	76F92	76F92	76F92
45	PAINT,BULK, GDP188, ALUM.....	0.125	28H284	28H284	28H194
*54	SHIM .003".....	1	200GAF732	200GAF732	200GAF732
55	SHIM .010".....	1	201GAF732	201GAF732	201GAF732
*56	SHIM .0015/.002".....	1	202GAF732	202GAF732	202GAF732
76	ADHESIVE.....	1	25BC885	25BC885	25BC885
81	DOWEL PIN.....	2	62M22	62M22	62M22
83	SLINGER.....	2	300GAF173	300GAF173	300GAF173
84	SCREW.....	2	75LM14	75LM14	75LM14
85	RETAINER.....	2	300GAF205	300GAF205	300GAF205
86	SCREW.....	8	75LM214	75LM214	75LM214
87	NUT.....	2	TST000179	TST000179	TST000179
Δ **105	KIT OVERHAUL – 6" R&S VERS LS DUAL-SPL	1	304GAF6010	304GAF6010	304GAF6010
**900	IDENT & INSTR GROUP.....	1	202GAF4011	202GAF4011	202GAF4011

* INCLUDED IN OVERHAUL KIT.

** NOT SHOWN ON ILLUSTRATION

Δ OVERHAUL KITS WILL HAVE EXTRA O-RINGS OR GASKETS. THIS DEPENDS ON MODEL NUMBER.

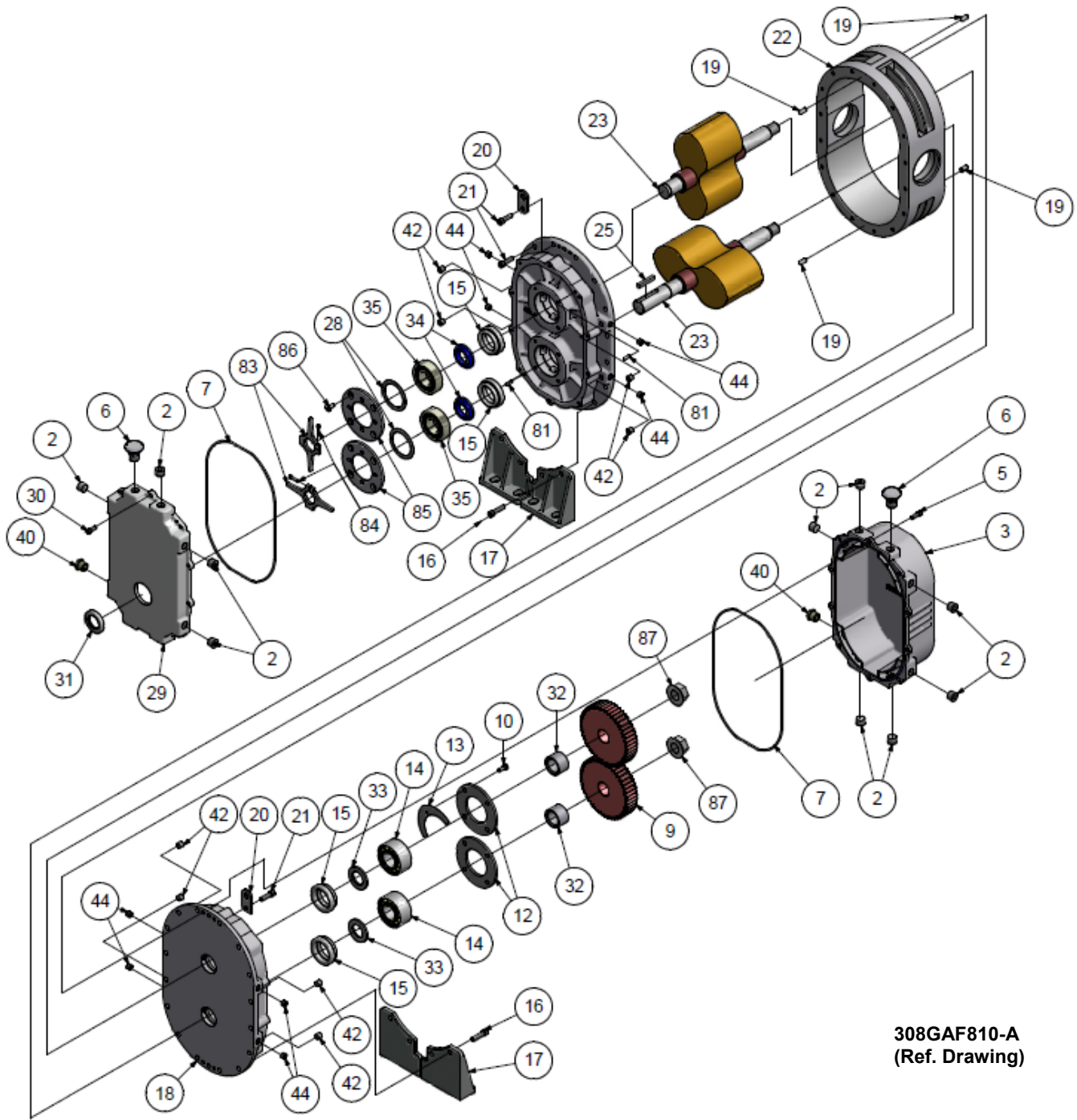

308GAF810-A
(Ref. Drawing)

Order by Part Number and Description. Reference Numbers are for your convenience only.

Ref. No.	Model GAF Description	Mechanical Seal No. Req'd	Dual Splash Lube		
			Size – 6H GAFH_S Δ Δ= (E or G)	Size – 6M GAFH_S Δ Δ= (E or G)	Size -- 6L GAFH_S Δ Δ= (E or G)
2	PLUG.....	12	64AC4	64AC4	64AC4
3	GEAR CASE.....	1	303GAF602	303GAF602	303GAF602
5	SCREW.....	10	75P40	75P40	75P40
6	BREATHER.....	2	5L223	5L223	5L223
*7	O-RING.....	2	TEN010748	TEN010748	TEN010748
9	GEAR KIT.....	1	302GAF6008	302GAF6008	302GAF6008
*10	SCREW.....	8	75A33P	75A33P	75A33P
12	BEARING RETAINER.....	2	900883065501	900883065501	900883065501
13	THRUST SHIM .020".....	4	900881065408	900881065408	900881065408
*13	SHIM SET.....	1	900881065400	900881065400	900881065408
*14	MAIN BEARING.....	2	900639080506	900639080506	900639080506
*15	MECHANICAL SEAL.....	4	900871020006	900871020006	900871020006
16	SCREW.....	8	75P57	75P57	75P57
17	GRP-FOOT, LEFT/RIGHT.....	1	306GAF166	306GAF166	306GAF166
18	HOUSING-BEARING GEAR END.....	1	304GAF006	304GAF006	304GAF006
19	DOWEL PIN.....	4	62M48	62M48	62M48
20	LUG.....	2	201GAF451	201GAF451	201GAF451
21	SCREW.....	24	75P56	75P56	75P56
22	CYLINDER.....	1	900883063901	900883064001	900883064101
23	ROTOR GROUP.....				
	6" Standard Clearance.....	1	318GAF4028	319GAF4028	320GAF4028
	6" High Temperature Clearance.....	1	TO BE ASSIGNED	TO BE ASSIGNED	TO BE ASSIGNED
24	HOUSING-BEARING DRIVE END.....	1	305GAF006	305GAF006	305GAF006
25	SQUARE KEY.....	1	900639910406	900639910406	900639910406
*28	WAVY SPRING.....	2	900669170506	900669170506	900669170506
29	DRIVE COVER.....	1	302GAF477	302GAF477	302GAF477
30	SCREW.....	10	75P40	75P40	75P40
*31	OIL SEAL.....	1	60DD658	60DD658	60DD658
32	GEAR SPACER.....	2	300GAF144	300GAF144	300GAF144
33	SEAL SPACER.....	2	900881066201	900881066201	900881066201
34	SPACER.....	2	301GAF144	301GAF144	301GAF144
*35	BEARING.....	2	900811060801	900811060801	900811060801
40	OIL LEVEL GAUGE.....	2	40P31	40P31	40P31
42	PLUG.....	8	64AC2	64AC2	64AC2
44	SCREW.....	8	76F92	76F92	76F92
45	PAINT,BULK,GDP188, ALUMINUM.....	0.125	28H284	28H284	28H284
53	PLUG.....	2	8503064	64EB750	200GDF6015
*54	SHIM .003".....	1	200GAF732	200GAF732	200GAF732
55	SHIM .010".....	1	201GAF732	201GAF732	201GAF732
*56	SHIM .0015/.002".....	1	202GAF732	202GAF732	202GAF732
76	ADHESIVE-LOCTITE.....	1	25BC885	25BC885	25BC885
81	DOWEL PIN.....	2	62M22	62M22	62M22
83	SLINGER.....	2	300GAF173	300GAF173	300GAF173
84	SCREW.....	2	75LM14	75LM14	75LM14
85	RETAINER BEARING.....	2	300GAF205	300GAF205	300GAF205
86	SCREW.....	8	75LM214	75LM214	75LM214
87	NUT.....	2	TST000179	TST000179	TST000179
Δ **105	KIT-OVERHAUL – 6" R&S VERSION MS DUAL.....	1	307GAF6010	307GAF6010	307GAF6010
**900	GROUP-IDENT & INSTR.....	1	202GAF4011	202GAF4011	202GAF4011

* INCLUDED IN OVERHAUL KIT.

** NOT SHOWN ON ILLUSTRATION

Δ OVERHAUL KITS WILL HAVE EXTRA O-RINGS OR GASKETS. THIS DEPENDS ON MODEL NUMBER.



**WARRANTY
SUTORBILT BLOWERS
Legend SERIES**

GENERAL PROVISIONS AND LIMITATIONS

Gardner Denver (the "Company") warrants to each original retail purchaser ("Purchaser") of its products from the Company or its authorized distributor that such products are, at the time of delivery to the Purchaser, made with good material and workmanship. No warranty is made with respect to:

1. Any product which has been repaired or altered in such a way, in the Company's judgment, as to affect the product adversely.
2. Any product which has, in the Company's judgment, been subject to negligence, accident, improper storage, or improper installation or application.
3. Any product which has not been operated or maintained in accordance with the recommendations of the Company.
4. Components or accessories manufactured, warranted and serviced by others.
5. Any reconditioned or prior owned product.

Claims for items described in (4) above should be submitted directly to the manufacturer.

WARRANTY PERIOD

The Company's obligation under this warranty is limited to repairing or, at its option, replacing, during normal business hours at an authorized service facility of the Company, any part which in its judgment proved not to be as warranted within the applicable Warranty Period as follows.

BARE BLOWERS

Basic grease lubricated bare blowers, consisting of all parts within, are warranted for 18 months from date of initial use or 24 months from date of shipment to the first purchaser, whichever occurs first. Basic dual splash lubricated bare blowers, consisting of all parts within, are warranted for 24 months from date of initial use or 30 months from date of shipment to the first purchaser, whichever occurs first. Any disassembly or partial disassembly of the blower, or failure to return the "unopened" blower per Company instructions, will be cause for denial of warranty.

OTHER COMPONENTS

All other components are warranted for 12 months from date of initial use or 18 months from date of shipment to first purchaser, whichever comes first. The Company reserves the right to withdraw the Warranty where evidence indicates application outside the stated performance area, or where there is evidence of abuse

LABOR TRANSPORTATION AND INSPECTION

The Company will provide labor, by Company representative or authorized service personnel, for repair or replacement of any product or part thereof which in the Company's judgment is proved not to be as warranted. Labor shall be limited to the amount specified in the Company's labor rate schedule.

Labor costs in excess of the Company rate schedules caused by, but not limited to, location or inaccessibility of equipment, or labor provided by unauthorized service personnel is not provided by this warranty.

All costs of transportation of product, labor or parts claimed not to be as warranted and, of repaired or replacement parts to or from such service facilities shall be borne by the Purchaser. The Company may require the return of any part claimed not to be as warranted to one of its facilities as designated by the Company, transportation prepaid by Purchaser, to establish a claim under this warranty. Replacement parts provided under the terms of the warranty are warranted for the remainder of the Warranty Period of the product upon which installed to the same extent as if such parts were original components.

DISCLAIMER

THE FOREGOING WARRANTY IS EXCLUSIVE AND IT IS EXPRESSLY AGREED THAT, EXCEPT AS TO TITLE, THE COMPANY MAKES NO OTHER WARRANTIES, EXPRESSED, IMPLIED OR STATUTORY, INCLUDING ANY IMPLIED WARRANTY OF MERCHANTABILITY.

THE REMEDY PROVIDED UNDER THIS WARRANTY SHALL BE THE SOLE, EXCLUSIVE AND ONLY REMEDY AVAILABLE TO THE PURCHASER AND IN NO CASE SHALL THE COMPANY BE SUBJECT TO ANY OTHER OBLIGATIONS OR LIABILITIES. UNDER NO CIRCUMSTANCES SHALL THE COMPANY BE LIABLE FOR ANY SPECIAL, INDIRECT, INCIDENTAL OR CONSEQUENTIAL DAMAGES, EXPENSES, LOSSES OR DELAYS HOWSOEVER CAUSED.

No statement, representation, agreement, or understanding, oral or written, made by any agent, distributor, representative, or employee of the Company which is not contained in this Warranty will be binding upon the Company unless made in writing and executed by an officer of the Company.

This warranty shall not be effective as to any claim which is not presented within 30 days after the date upon which the product is claimed not to have been as warranted. Any action for breach of this warranty must be commenced within one year after the date upon which the cause of action occurred.

Any adjustment made pursuant to this warranty shall not be construed as an admission by the Company that any product was not as warranted.



C. Emery Nelson, Inc.
INDUSTRIAL AND POWER PLANT EQUIPMENT

7631 Commerce Street, Hamel, MN 55340
Ph: 763/ 420-3844 Fax: 763/420-2542

**Gardner
Denver®**

Gardner Denver, Inc.

1800 Gardner Expressway
Quincy, IL 62305

Customer Service Department
Telephone: (800) 682-9868
pd.blowers@gardnerdenver.com

www.gardnerdenverproducts.com