

ZONE		REVISION HISTORY		DATE	DWN	CHK
A		RELEASED PER ECN 1041337				



# C. Emery Nelson, Inc.

INDUSTRIAL AND POWER PLANT EQUIPMENT

7631 Commerce Street, Hamel, MN 55340  
Ph: 763/420-3844 Fax: 763/420-2542

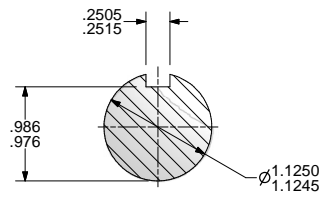
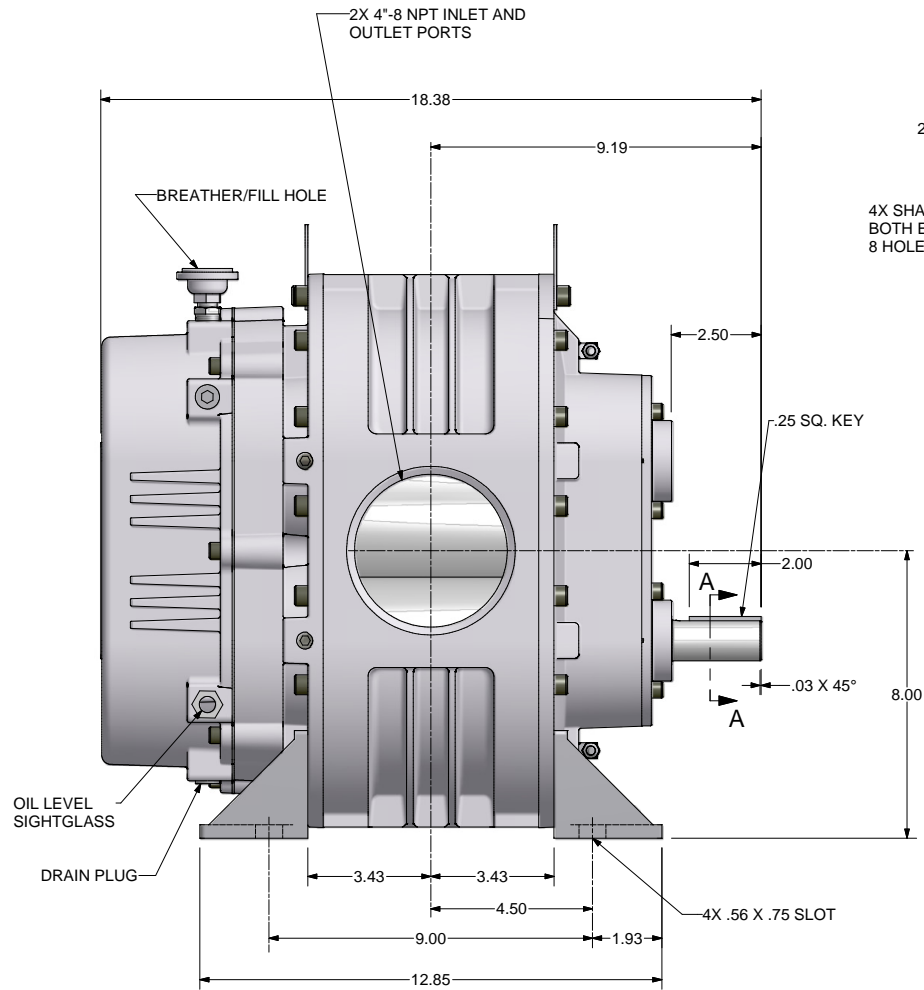

SECTION A-A  
SCALE 2 : 1

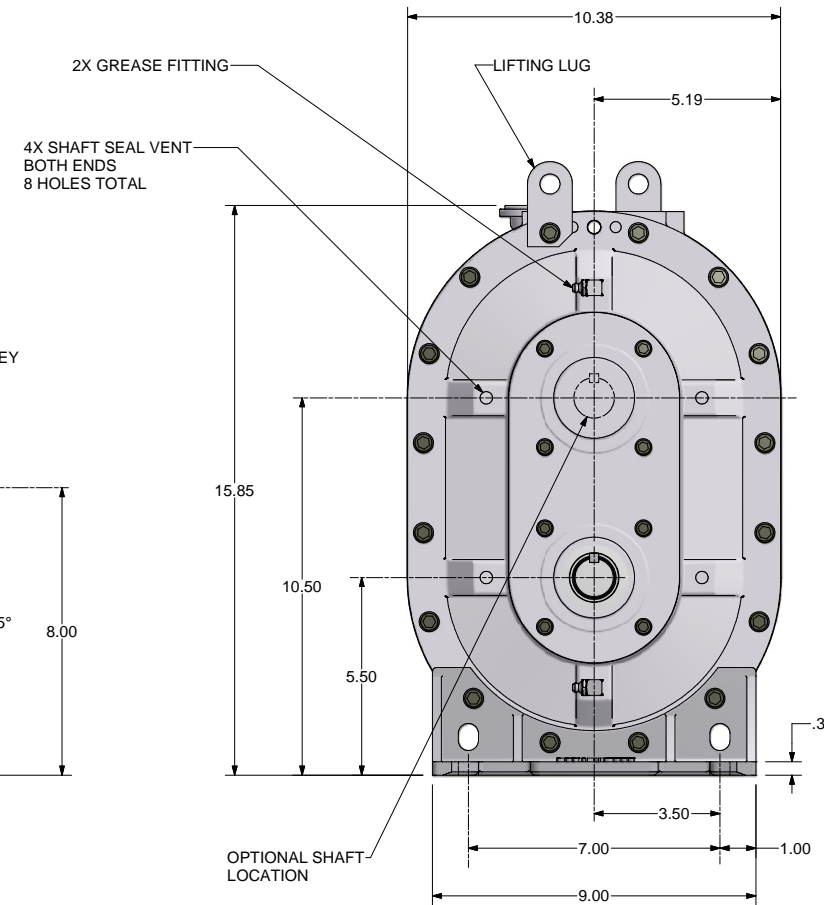

ALL ROTATIONS AND PORT LOCATIONS WHEN FACING SHAFT END

CONSTRUCTION	ROTATION	DISCHARGE PORT
VERTICAL BOTTOM	CLOCK WISE (CW) COUNTERCLOCKWISE (CCW)	LEFT SIDE RIGHT SIDE
VERTICAL TOP	CLOCKWISE (CW) COUNTERCLOCKWISE (CCW)	RIGHT SIDE LEFT SIDE

FINISH OF CHAMBERS AND FLEETS TO CONFORM TO DIMENSIONS ARE IN INCHES  
TOL. ON DECIMALS: X = ± .05  
TOL. ON DECIMALS: XX = ± .02  
TOL. ON DECIMALS: XXX = ± .01 AS SPECIFIED  
TOL. ON ANGLES: ± 0.30

UNLESS OTHERWISE SPECIFIED  
DIMENSIONS ARE IN INCHES  
TOL. ON DECIMALS: X = ± .05  
TOL. ON DECIMALS: XX = ± .02  
TOL. ON DECIMALS: XXX = ± .01 AS SPECIFIED  
TOL. ON ANGLES: ± 0.30

CONFIDENTIAL: THE INFORMATION CONTAINED IN THIS DOCUMENT IS THE PROPERTY OF GARDNER DENVER, INC. IT IS NOT FOR PUBLIC DISCLOSURE. POSSESSION OF THE INFORMATION DOES NOT CONFER ANY RIGHT TO LOAN, REPRODUCE, OR DISCLOSE THE INFORMATION. UNAUTHORIZED REPRODUCTION OR USE OF THE INFORMATION IS PROHIBITED. THIS DOCUMENT IS TO BE RETURNED TO GARDNER DENVER, INC. UPON THE COMPLETION OF THE PURPOSE FOR WHICH IT IS LOANED OR UPON REQUEST.

DIMENSIONING AND TOLERANCING PER ASME Y14.5M-1994  
THREADS PER ASME B1.1 (CALCULATED) 21 UN-2B AND B1.20.1 & B1.20.3

HEAT TREATMENT: ENG. REF. A

**Gardner Denver**  
SMVR LEGEND GRS-SPL  
OUTLINE-BARE UNIT

DWN BY: RNS 01/11/2008  
E: WSC  
C/D BY: RNS 01/11/2008

319GAE800