



C. Emery Nelson, Inc.

INDUSTRIAL AND POWER PLANT EQUIPMENT

7631 Commerce Street, Hamel, MN 55340
 Ph: 763/420-3844 Fax: 763/420-2542

ZONE		REVISION HISTORY		DATE	DWN	CHK
A		RELEASED PER ECN 1041337				

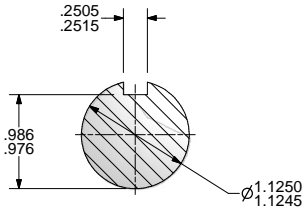
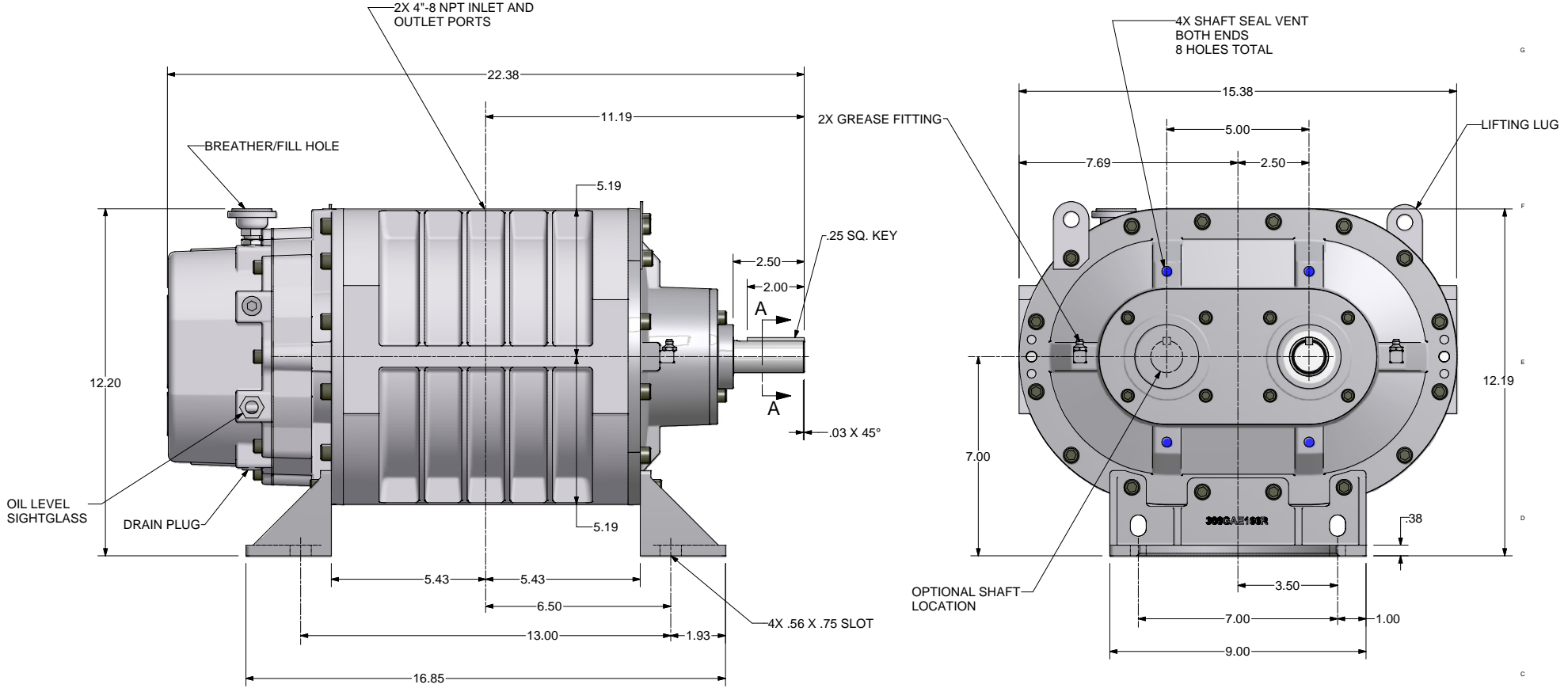

SECTION A-A
SCALE 2 : 1

ALL ROTATIONS AND PORT LOCATIONS WHEN FACING SHAFT END

CONSTRUCTION	ROTATION	DISCHARGE PORT
HORIZONTAL RIGHT	CLOCK WISE (CW)	BOTTOM SIDE
	COUNTERCLOCKWISE (CCW)	TOP SIDE
HORIZONTAL LEFT	CLOCKWISE (CW)	TOP SIDE
	COUNTERCLOCKWISE (CCW)	BOTTOM SIDE

FINISH OF CHAMBERS AND FLEETS TO CONFORM TO ROUGHENED SURFACE AREA. SURFACE ROUGHNESS MAXIMUM PER ASME B46.1. FULL THREAD DEPTH ARE MAXIMUM.

UNLESS OTHERWISE SPECIFIED DIMENSIONS ARE IN INCHES
 TOL. ON DECIMALS: X = ± .05
 TOL. ON DECIMALS: XX = ± .02
 TOL. ON DECIMALS: XXX = ± .01 AS SPECIFIED
 TOL. ON ANGLES: ± 0.30

THIRD ANGLE PROJECTION

CONFIDENTIAL: THE INFORMATION CONTAINED IN THIS DOCUMENT IS THE PROPERTY OF GARDNER DENVER, INC. IT IS NOT FOR PUBLIC DISCLOSURE. POSSESSION OF THE INFORMATION DOES NOT CONVEY ANY RIGHT TO LOAN, REPRODUCE, OR DISCLOSE THE INFORMATION. UNAUTHORIZED REPRODUCTION OR USE OF THE INFORMATION IS PROHIBITED. THIS DOCUMENT IS TO BE RETURNED TO GARDNER DENVER, INC. UPON THE COMPLETION OF THE PURPOSE FOR WHICH IT IS LOANED OR UPON REQUEST.

DIMENSIONING AND TOLERANCING PER ASME Y14.5M-1994
 THREADS PER ASME B1.1 GRADING SYSTEM Z1 UN UNF. ANSI B1.20.1 & B1.20.3

Gardner Denver Inc. Quincy, IL	HEAT TREATMENT	ENG. REF. A
DWN BY: RNS 6/12/2008	SIR LEGEND GRS-SPL	
CRD BY: RNS 6/12/2008	WCS	322GAE800