

REVISION HISTORY		DATE	DWN	CHK
ZONE	REV	DESCRIPTION		
	A	RELEASED PER ECN 1040966		



C. Emery Nelson, Inc.

INDUSTRIAL AND POWER PLANT EQUIPMENT

7631 Commerce Street, Hamel, MN 55340
 Ph: 763/ 420-3844 Fax: 763/420-2542

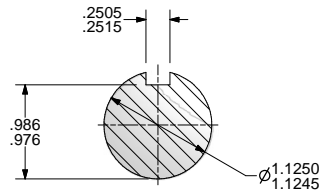
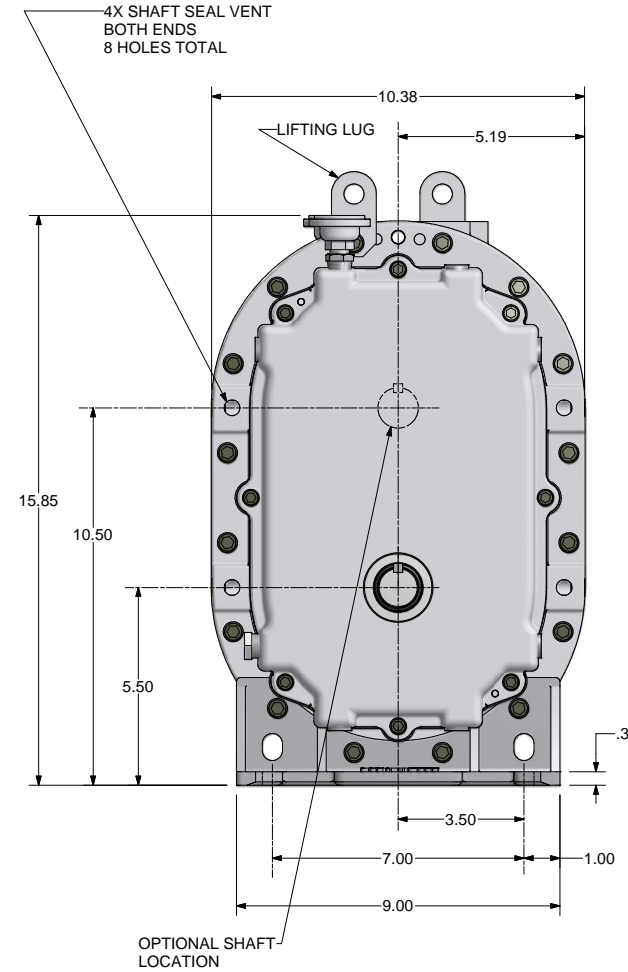
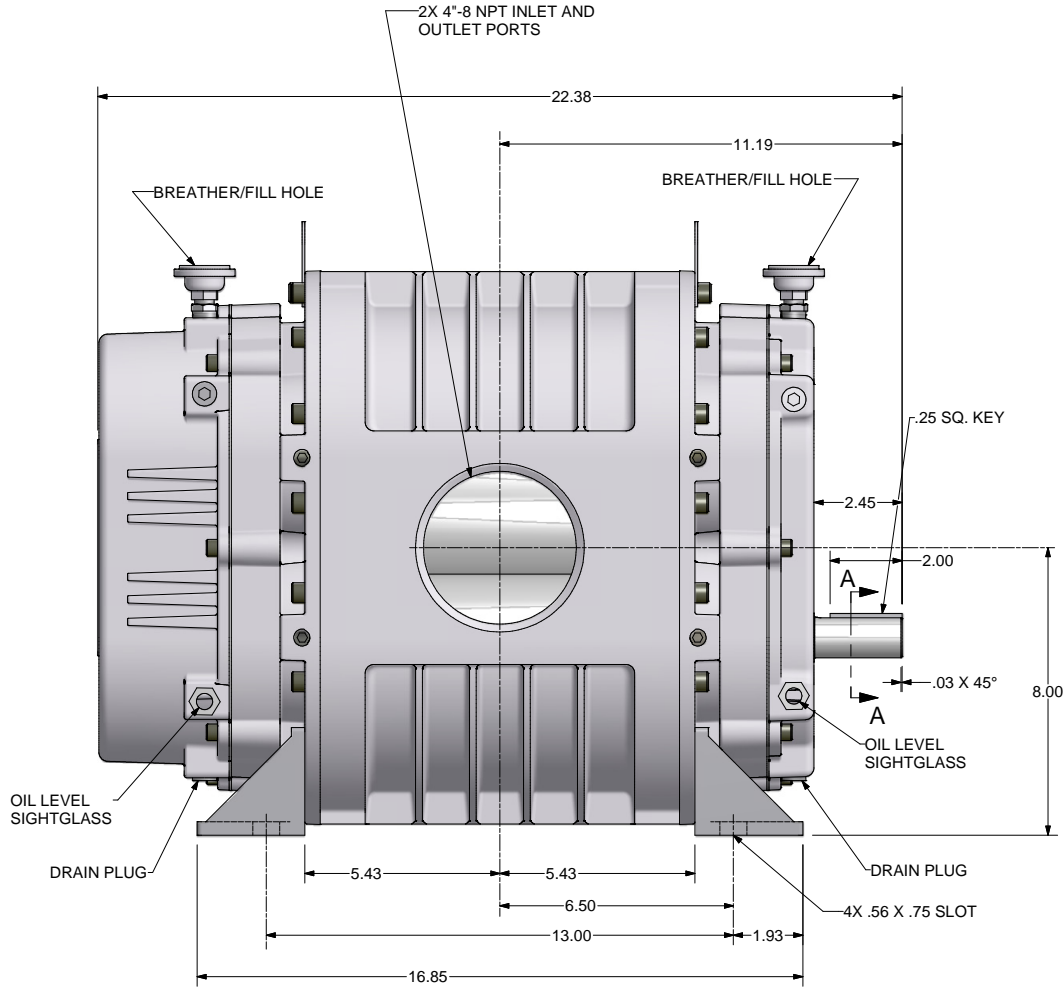

SECTION A-A
SCALE 2 : 1

ALL ROTATIONS AND PORT LOCATIONS WHEN FACING SHAFT END

CONSTRUCTION	ROTATION	DISCHARGE PORT
VERTICAL BOTTOM	CLOCK WISE (CW) COUNTERCLOCKWISE (CCW)	LEFT SIDE RIGHT SIDE
VERTICAL TOP	CLOCKWISE (CW) COUNTERCLOCKWISE (CCW)	RIGHT SIDE LEFT SIDE

FINISH OF CHAMBERS AND FLEETS TO CONFORM TO ROUGHENED SURFACE AREA.

UNLESS OTHERWISE SPECIFIED DIMENSIONS ARE IN INCHES

TOL. ON DECIMALS: .X = ± .05
 TOL. ON DECIMALS: .XX = ± .02
 TOL. ON DECIMALS: .XXX = ± .01
 TOL. ON ANGLES: ± 0.30°

CONFIDENTIAL: THE INFORMATION CONTAINED IN THIS DOCUMENT IS THE PROPERTY OF GARDNER DENVER, INC. IT IS NOT FOR PUBLIC DISCLOSURE. POSSESSION OF THE INFORMATION DOES NOT CONFER ANY RIGHT TO LOAN, REPRODUCE, OR DISCLOSE THE INFORMATION. UNAUTHORIZED REPRODUCTION OR USE OF THE INFORMATION IS PROHIBITED. THIS DOCUMENT IS TO BE RETURNED TO GARDNER DENVER, INC. UPON THE COMPLETION OF THE PURPOSE FOR WHICH IT IS LOANED OR UPON REQUEST.

DIMENSIONING AND TOLERANCING PER ASME Y14.5M-1994
 THREADS PER ASME B1.1 (SAE SYSTEM 2) UN-2B AND B1.203 (B & B) 20.3

HEAT TREATMENT: SLVR LEGEND DSL
 TITLE: OUTLINE-BARE UNIT

Gardner Denver Inc. Quincy, IL
 DWN BY: RNS 5/20/2008
 E: WSC
 CTD BY: RNS 5/20/2008

315GAE800