

REVISION HISTORY		DATE	DWN	CHK
ZONE	REV	DESCRIPTION		
	A	RELEASED PER ECN 1042555		

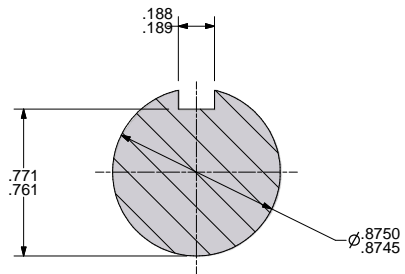
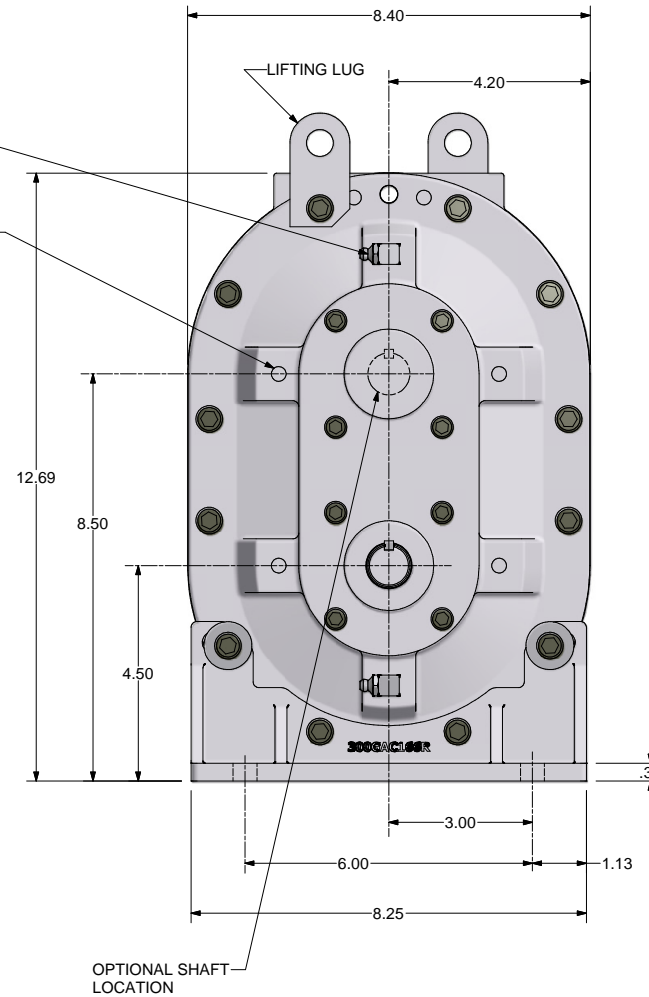
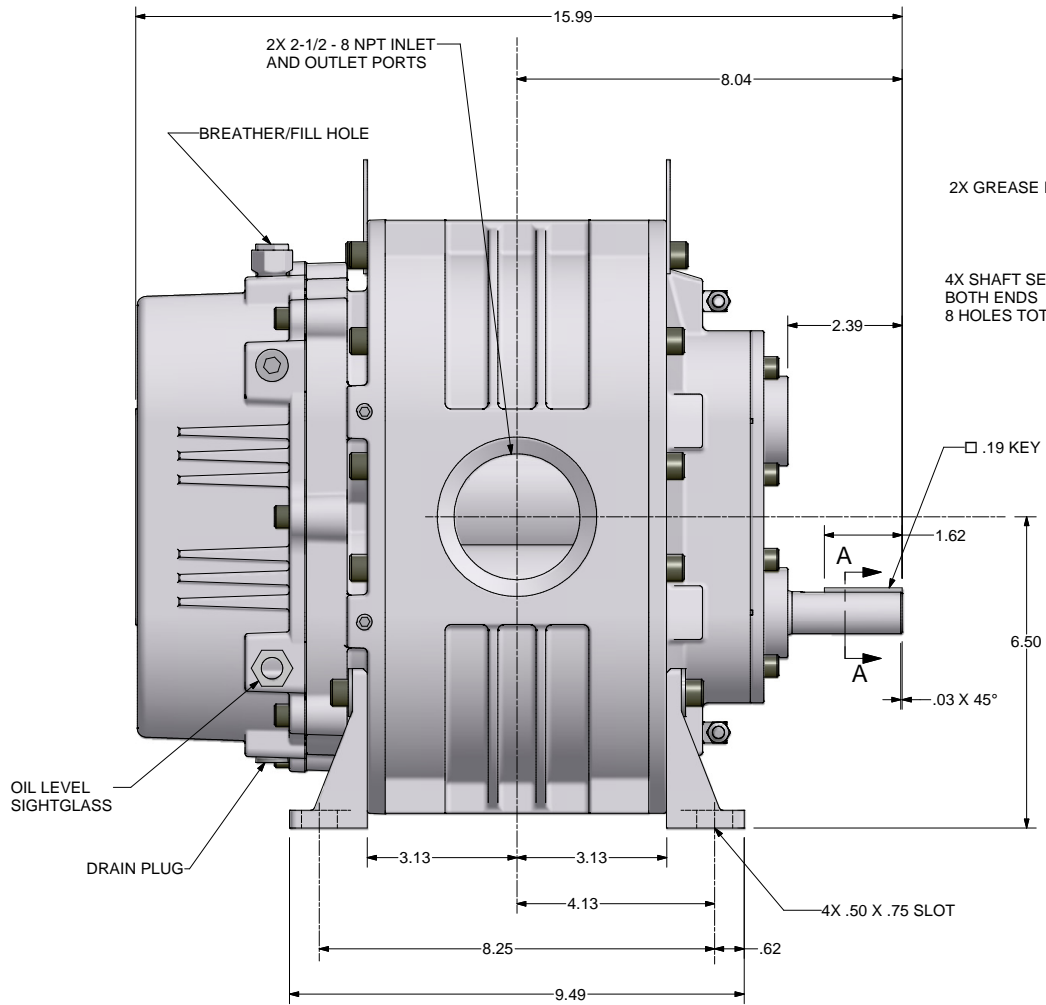

SECTION A-A
SCALE 4 : 1

ALL ROTATIONS AND PORT LOCATIONS WHEN FACING SHAFT END

CONSTRUCTION	ROTATION	DISCHARGE PORT
VERTICAL BOTTOM	CLOCK WISE (CW)	LEFT SIDE
	COUNTERCLOCKWISE (CCW)	RIGHT SIDE
VERTICAL TOP	CLOCKWISE (CW)	RIGHT SIDE
	COUNTERCLOCKWISE (CCW)	LEFT SIDE

FINISH OF CHAMFERS AND FILLETS TO CONFORM TO DIMENSIONS AND TOLERANCING PER ASME Y14.5M-1994. SURFACE ROUGHNESS MAXIMUM PER ASME B46.1. FULL THREAD DEPTH ARE MAXIMUM.

UNLESS OTHERWISE SPECIFIED DIMENSIONS ARE IN INCHES
TOL. ON DECIMALS: .X = ± .05
TOL. ON DECIMALS: .XX = ± .02
TOL. ON DECIMALS: .XXX = ± .01
TOL. ON ANGLES: ± 0.30°

CONFIDENTIAL: THE INFORMATION CONTAINED IN THIS DOCUMENT IS THE PROPERTY OF GARDNER DENVER, INC. IT IS NOT FOR PUBLIC DISCLOSURE. POSSESSION OF THE INFORMATION DOES NOT CONVEY ANY RIGHT TO LOAN, REPRODUCE, OR DISCLOSE THE INFORMATION. UNAUTHORIZED REPRODUCTION OR USE OF THE INFORMATION IS PROHIBITED. THIS DOCUMENT IS TO BE RETURNED TO GARDNER DENVER, INC. UPON THE COMPLETION OF THE PURPOSE FOR WHICH IT IS LOANED OR UPON REQUEST.

DIMENSIONING AND TOLERANCING PER ASME Y14.5M-1994
THREADS PER ASME B1.1 (SAFETY SYSTEM 21.1) D1.1, ANSI B1.20.1 & B1.20.3

Gardner Denver Inc.	HEAT TREATMENT	ENG. REF. A
Quincy, IL	4MVR LEGEND GRS-SPL	
DWN BY: RNS 11/20/2008	WCS	326GAC800
CRD BY: RNS 11/20/2008	FULL	

THIRD ANGLE PROJECTION



C. Emery Nelson, Inc.
INDUSTRIAL AND POWER PLANT EQUIPMENT

7631 Commerce Street, Hamel, MN 55340
Ph: 763/420-3844 Fax: 763/420-2542