

ZONE		REV	REVISION HISTORY	DATE	DWN	CHK
		00	RELEASED PER ECN 1042521			
		01	& B1 CHANGED BREATHER STYLE; ECN 1048497	10-20-09	RRB	RNS
		02				

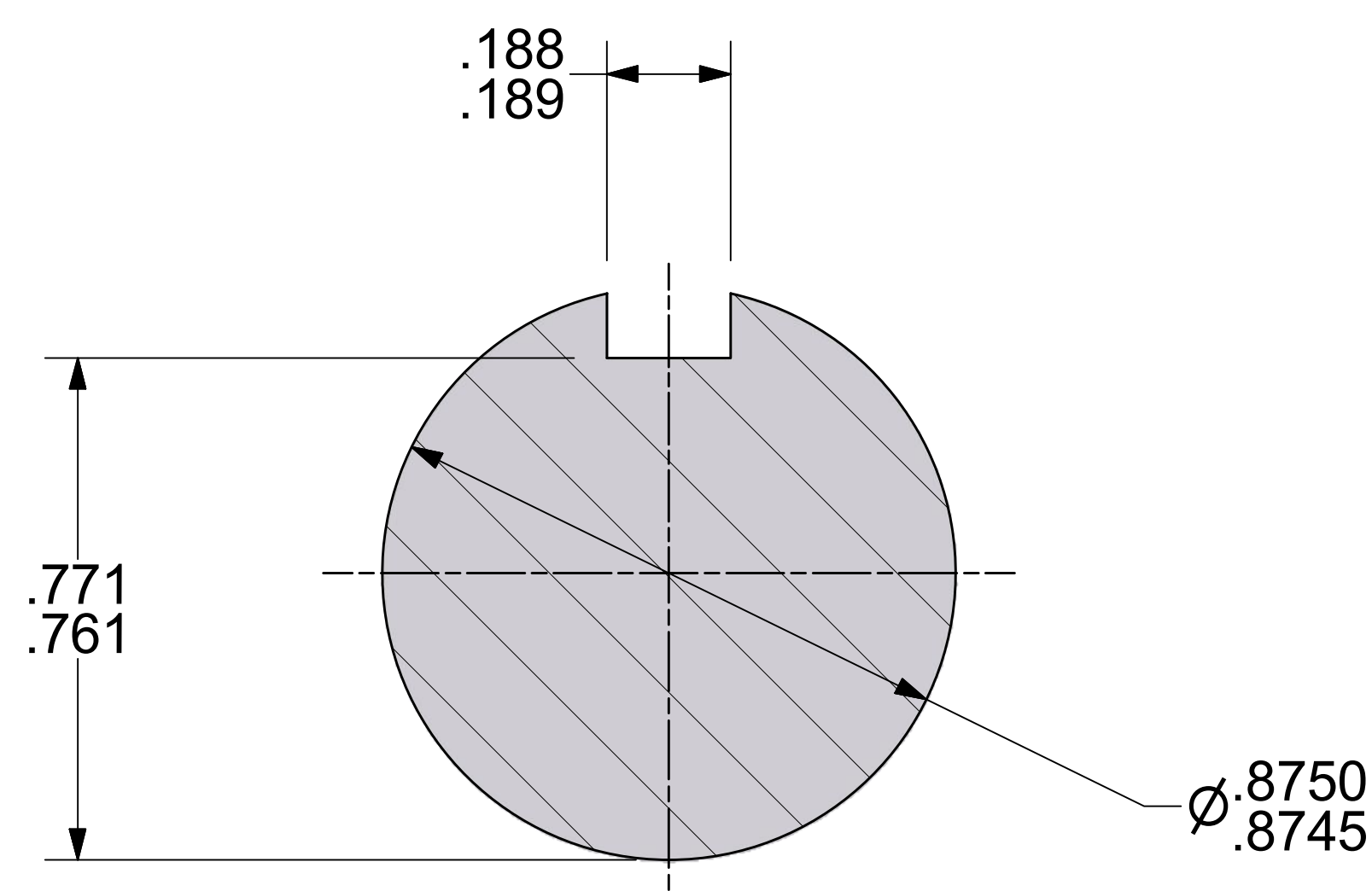
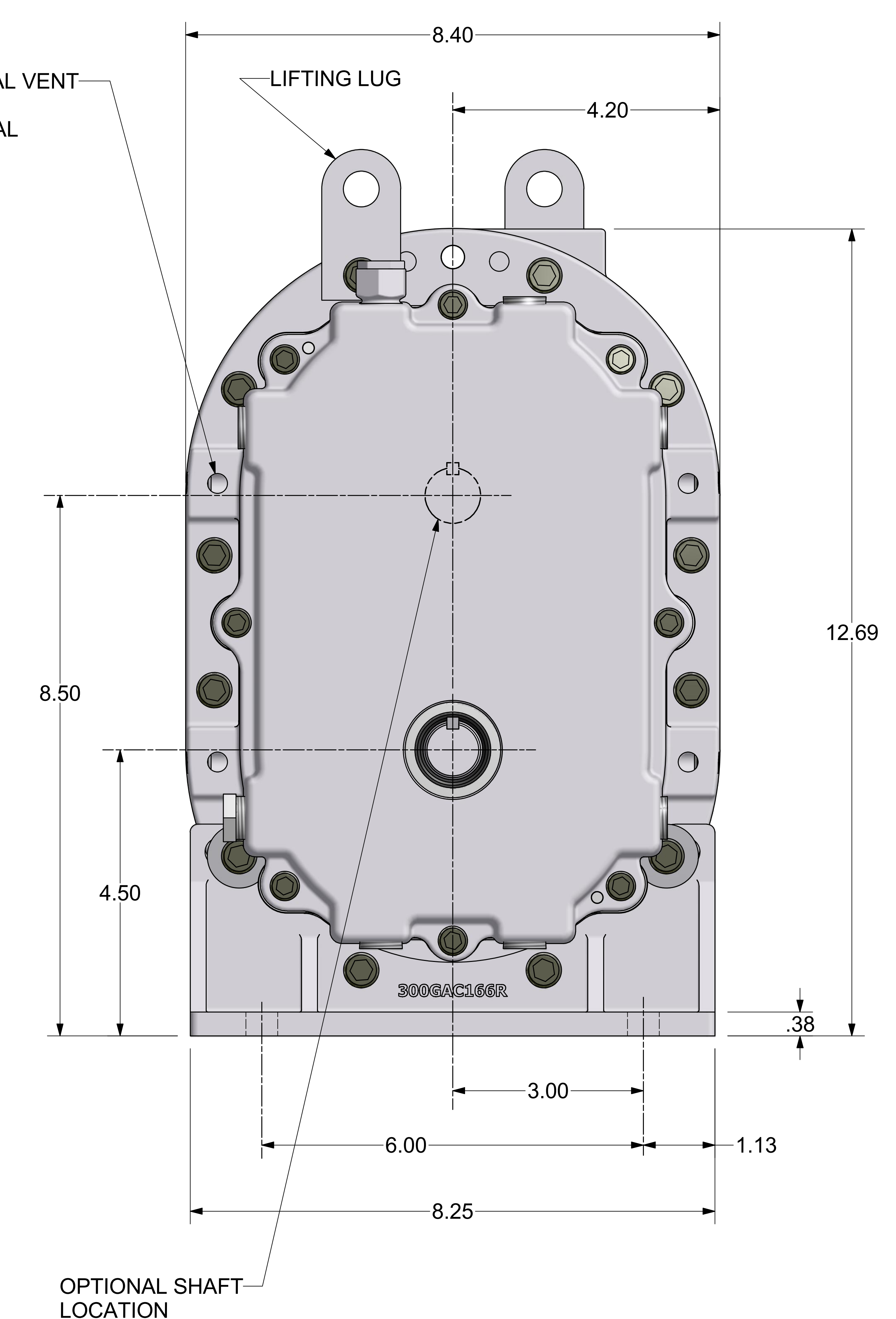
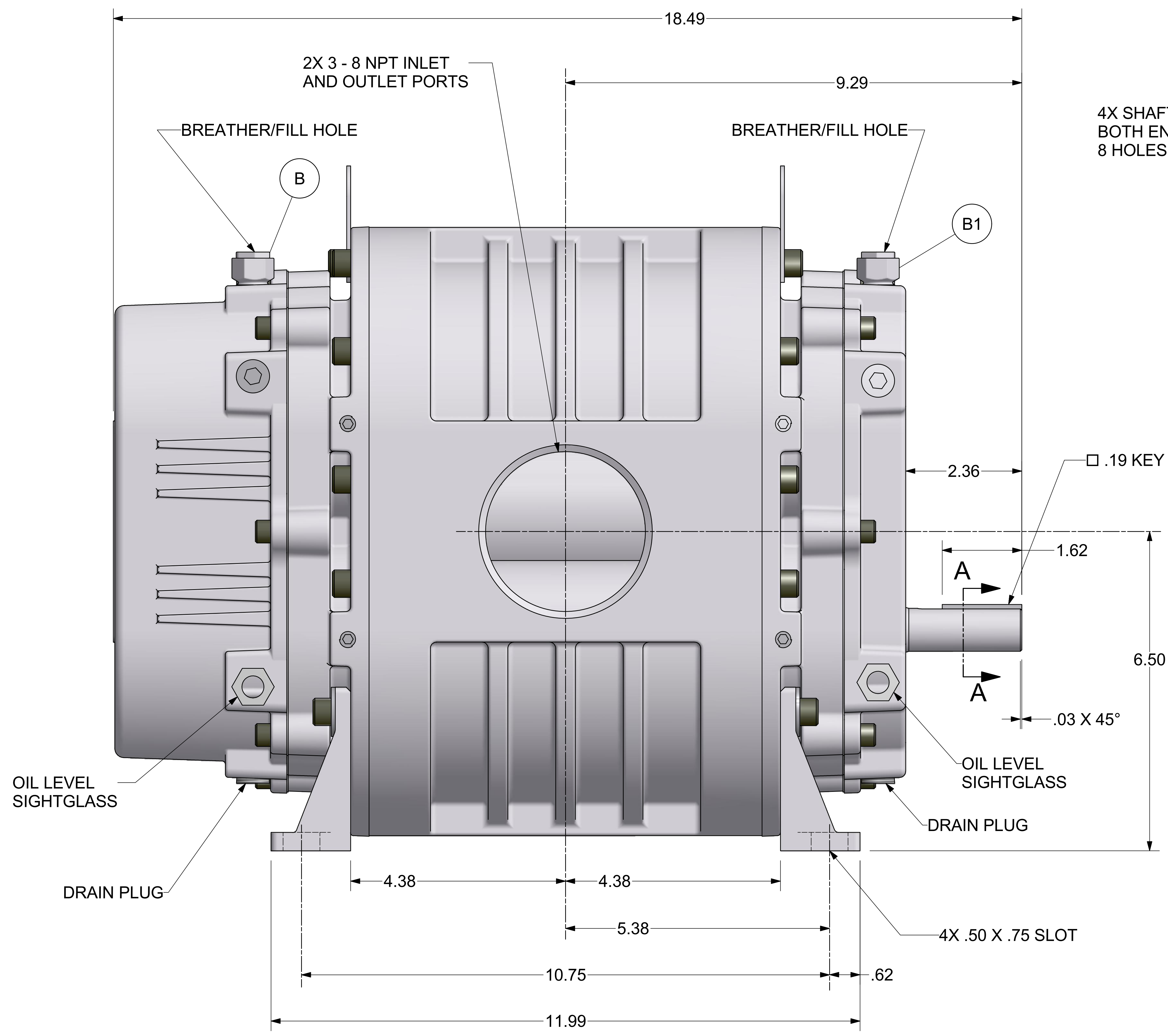

ALL ROTATIONS AND PORT LOCATIONS WHEN FACING SHAFT END

CONSTRUCTION	ROTATION	DISCHARGE PORT
VERTICAL BOTTOM	CLOCK WISE (CW)	LEFT SIDE
	COUNTERCLOCKWISE (CCW)	RIGHT SIDE
VERTICAL TOP	CLOCKWISE (CW)	RIGHT SIDE
	COUNTERCLOCKWISE (CCW)	LEFT SIDE

FINISH OF CHAMFERS AND FILLETS TO CONFORM TO ROUGHEST ADJACENT AREA. SURFACE ROUGHNESS MAXIMUM PER ASME B46.1. FULL THREAD DEPTHS ARE MINIMUM.

UNLESS OTHERWISE SPECIFIED DIMENSIONS ARE IN INCHES  
TOL. ON DECIMALS: X = ± .05  
TOL. ON DECIMALS: XX = ± .02  
TOL. ON DECIMALS: XXX = ± AS SPECIFIED  
TOL. ON ANGLES: ± 0°-30'

THIRD ANGLE PROJECTION

CONFIDENTIAL - THE INFORMATION CONTAINED IN THIS DOCUMENT IS THE PROPERTY OF GARDNER DENVER, INC. IT IS NOT FOR PUBLIC DISCLOSURE. POSSESSION OF THE INFORMATION DOES NOT CONVEY ANY RIGHT TO LOAN, SELL OR DISCLOSE THE INFORMATION UNAUTHORIZED REPRODUCTION OR USE OF THE INFORMATION IS PROHIBITED. THIS DOCUMENT IS TO BE RETURNED TO GARDNER DENVER, INC. UPON THE COMPLETION OF THE PURPOSE FOR WHICH IT IS LOANED OR UPON REQUEST.

DIMENSIONING AND TOLERANCING PER ASME Y14.5M-1994  
THREADS PER ASME B1.1 GAGING SYSTEM 21 U.O.S., ANSI B1.20.1 & B1.20.3

**Gardner Denver**  
Gardner Denver Inc.  
Quincy, IL  
DWN BY RRB 9/9/2008  
CKD BY RNS 9/9/2008

HEAT TREATMENT  
ENG. REF:  
TITLE: **OUTLINE-BARE UNIT**  
4LVS LEGEND DSL  
WCS  
**321GAC800**

SCALE: FULL  
SHEET 1 OF 1

**C. Emery Nelson, Inc.**  
INDUSTRIAL AND POWER PLANT EQUIPMENT

7631 Commerce Street, Hamel, MN 55340  
Ph: 763/ 420-3844 Fax: 763/420-2542