



# C. Emery Nelson, Inc.

INDUSTRIAL AND POWER PLANT EQUIPMENT

7631 Commerce Street, Hamel, MN 55340  
Ph: 763/420-3844 Fax: 763/420-2542

REVISION HISTORY		DATE	DWN	CHK
ZONE	REV	DESCRIPTION		
	A	RELEASED PER ECN 1042521		
	B	& B1 CHANGED BREATHER STYLE; B2 WAS 10.58 DIM TO TOP OF BREATHER; ECN 1048497	10-20-09	RRB RNS

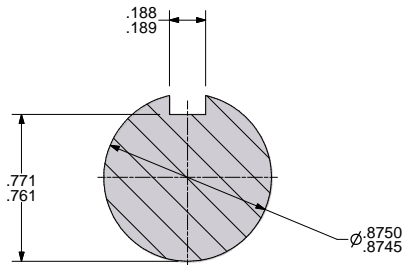
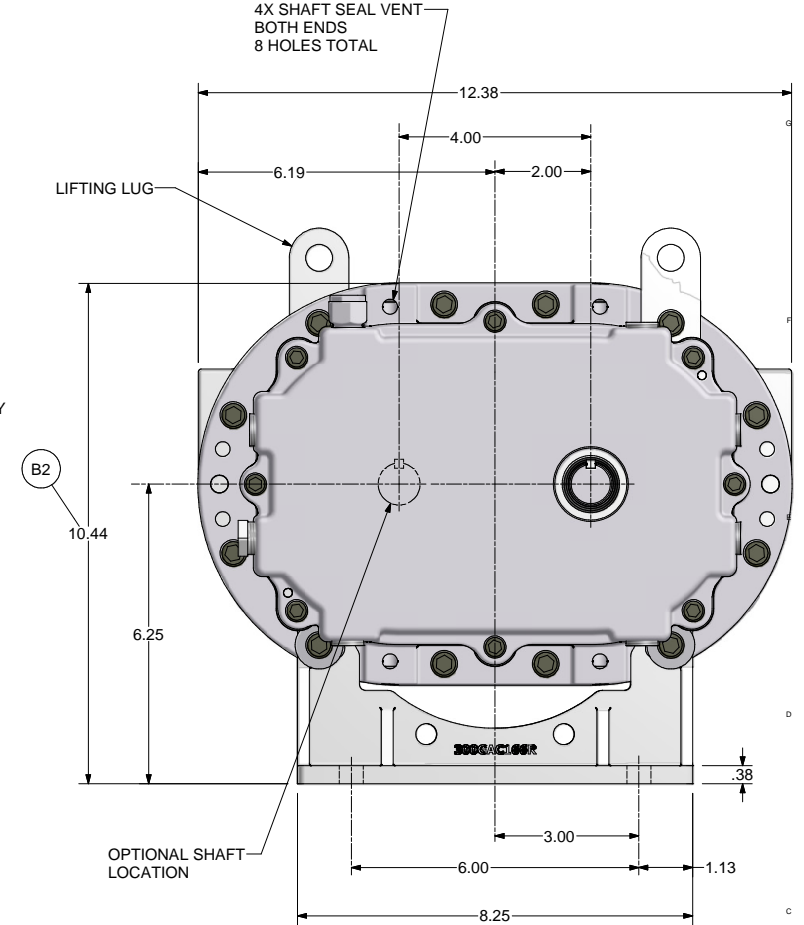
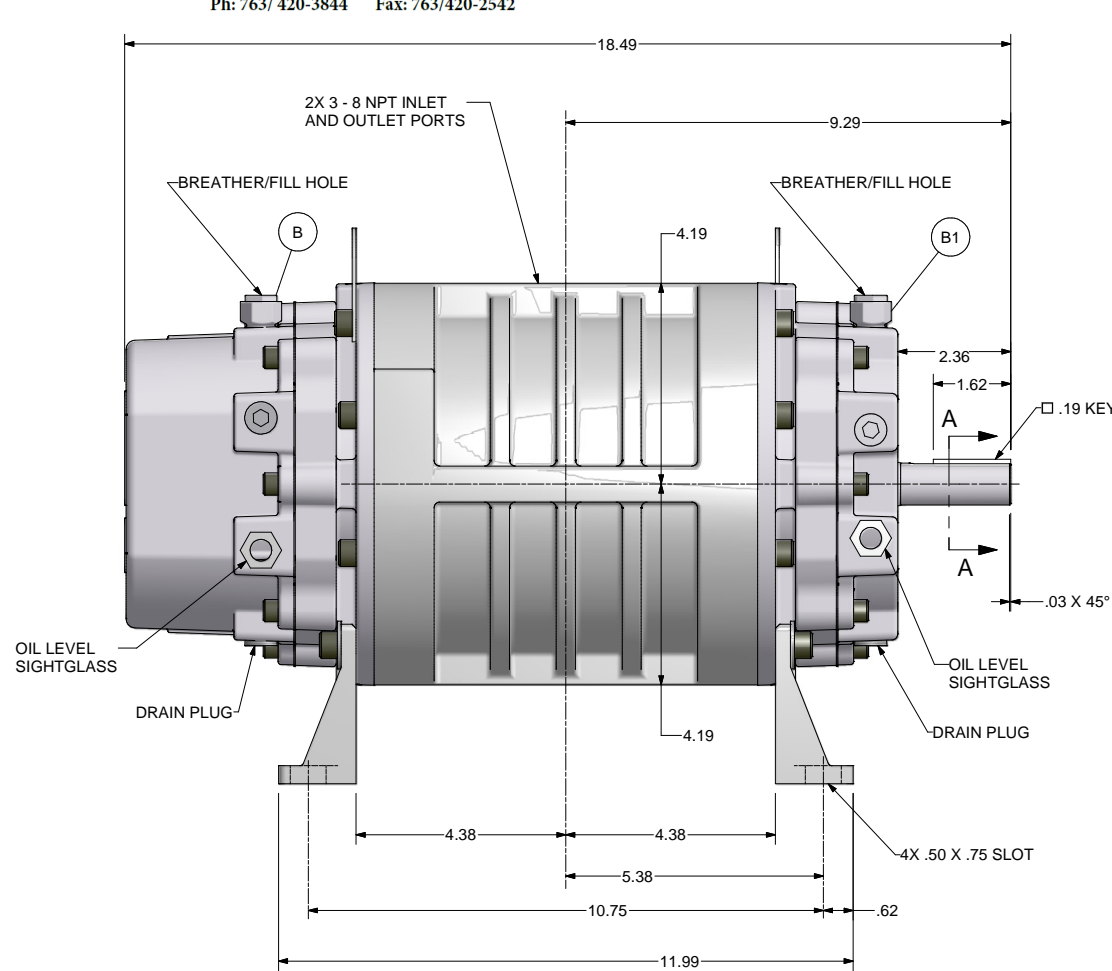

SECTION A-A  
SCALE 4 : 1

ALL ROTATIONS AND PORT LOCATIONS WHEN FACING SHAFT END

CONSTRUCTION	ROTATION	DISCHARGE PORT
HORIZONTAL RIGHT	CLOCK WISE (CW)	BOTTOM SIDE
	COUNTERCLOCKWISE (CCW)	TOP SIDE
HORIZONTAL LEFT	CLOCKWISE (CW)	TOP SIDE
	COUNTERCLOCKWISE (CCW)	BOTTOM SIDE

UNLESS OTHERWISE SPECIFIED DIMENSIONS ARE IN INCHES  
TOL. ON DECIMALS: .X = ± .05  
TOL. ON DECIMALS: .XX = ± .02  
TOL. ON DECIMALS: .XXX = ± .01  
TOL. ON ANGLES: ± 0.30

FINISH OF CHAMBERS AND FLEETS TO CONFORM TO ROUGHNESS RA MAXIMUM PER ASME B46.1. FULL THREAD DEPTHS ARE MAXIMUM.

CONFIDENTIAL: THE INFORMATION CONTAINED IN THIS DOCUMENT IS THE PROPERTY OF GARDNER DENVER, INC. IT IS NOT FOR PUBLIC DISCLOSURE. POSSESSION OF THE INFORMATION DOES NOT CONVEY ANY RIGHT TO LOAN, REPRODUCE, OR DISCLOSE THE INFORMATION. UNAUTHORIZED REPRODUCTION OR USE OF THE INFORMATION IS PROHIBITED. THIS DOCUMENT IS TO BE RETURNED TO GARDNER DENVER, INC. UPON THE COMPLETION OF THE PURPOSE FOR WHICH IT IS LOANED OR UPON REQUEST.

DIMENSIONING AND TOLERANCING PER ASME Y14.5M-1994  
THREADS PER ASME B1.1 (SAE SYSTEM) 21 UN-2.0 L1.0 L1.0 AND B1.20.1 & B1.20.3

Gardner Denver Inc. Quincy, IL	HEAT TREATMENT	ENG. REF. A
DWN BY: RNS 8/29/2008	4LR LEGEND DSG	
CRD BY: RNS 8/29/2008	WCS	318GAC800
	FULL	