



# C. Emery Nelson, Inc.

INDUSTRIAL AND POWER PLANT EQUIPMENT

7631 Commerce Street, Hamel, MN 55340  
Ph: 763/420-3844 Fax: 763/420-2542

REVISION HISTORY		DATE	DWN	CHK
ZONE	REV	DESCRIPTION		
	A	RELEASED PER ECN 1042555		

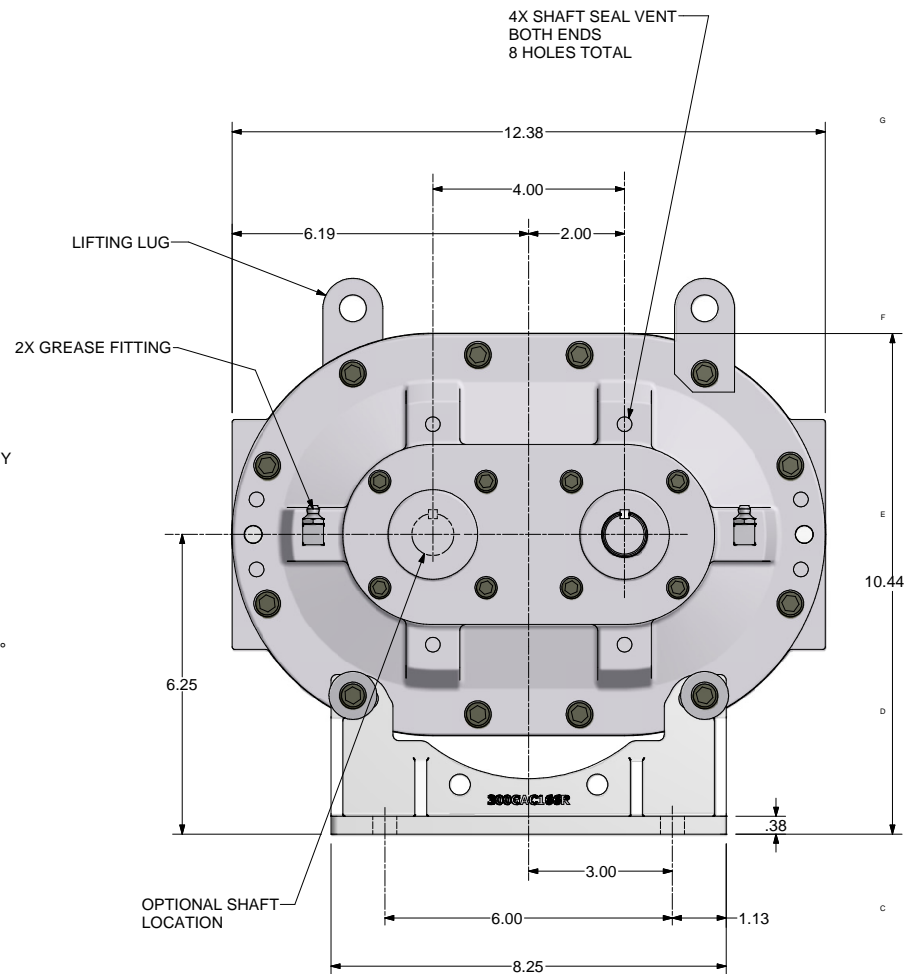
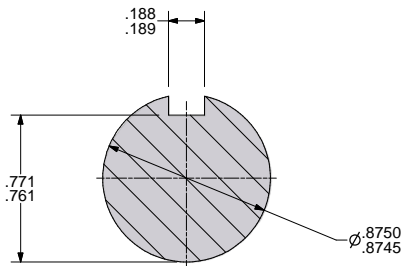
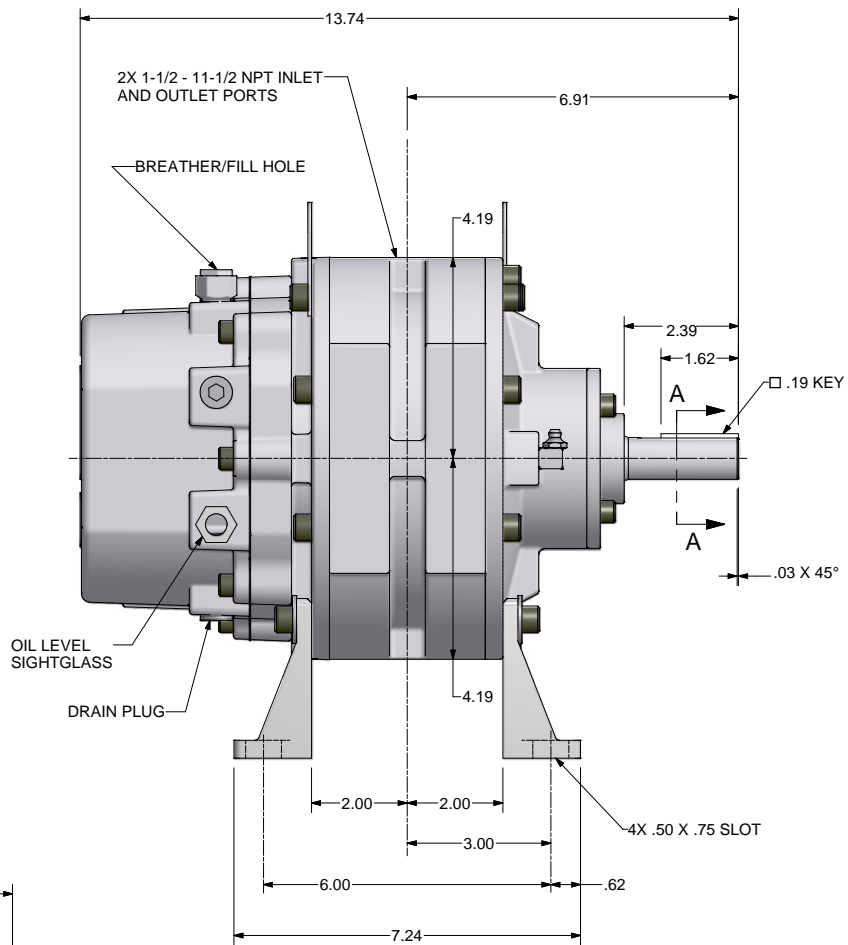

ALL ROTATIONS AND PORT LOCATIONS WHEN FACING SHAFT END

CONSTRUCTION	ROTATION	DISCHARGE PORT
HORIZONTAL RIGHT	CLOCK WISE (CW)	BOTTOM SIDE
	COUNTERCLOCKWISE (CCW)	TOP SIDE
HORIZONTAL LEFT	CLOCKWISE (CW)	TOP SIDE
	COUNTERCLOCKWISE (CCW)	BOTTOM SIDE

FINISH OF CHAMBERS AND FILLETS TO CONFORM TO ROUGHNESS RA MAXIMUM AREA.  
SURFACE ROUGHNESS MAXIMUM PER ASME B46.1. FULL THREAD DEPTH IS MAXIMUM.

UNLESS OTHERWISE SPECIFIED DIMENSIONS ARE IN INCHES  
TOL. ON DECIMALS: .X = ± .05  
TOL. ON DECIMALS: .XX = ± .02  
TOL. ON DECIMALS: .XXX = ± .01 AS SPECIFIED  
TOL. ON ANGLES: ± 0.30

CONFIDENTIAL: THE INFORMATION CONTAINED IN THIS DOCUMENT IS THE PROPERTY OF GARDNER DENVER, INC. IT IS NOT FOR PUBLIC DISCLOSURE. POSSESSION OF THE INFORMATION DOES NOT CONVEY ANY RIGHT TO LOAN, REPRODUCE, OR DISCLOSE THE INFORMATION. UNAUTHORIZED REPRODUCTION OR USE OF THE INFORMATION IS PROHIBITED. THIS DOCUMENT IS TO BE RETURNED TO GARDNER DENVER, INC. UPON THE COMPLETION OF THE PURPOSE FOR WHICH IT IS LOANED OR UPON REQUEST.

DIMENSIONING AND TOLERANCING PER ASME Y14.5M-1994  
THREADS PER ASME B1.1 CATALOG SYSTEM 21.1.0.1.3 AND B1.20.1 & B1.20.3

Gardner Denver Inc. Quincy, IL	HEAT TREATMENT	ENG. REF. A
TITLE OUTLINE-BARE UNIT	4HR LEGEND GRS-SPL	
DWN BY: RNS 11/20/2008	WCS	322GAC800
CRD BY: RNS 11/20/2008	FULL	

