

ZONE		REVISION HISTORY		DATE	DWN	CHK
A		RELEASED PER ECN 1045640				



# C. Emery Nelson, Inc.

INDUSTRIAL AND POWER PLANT EQUIPMENT

7631 Commerce Street, Hamel, MN 55340  
 Ph: 763/ 420-3844 Fax: 763/420-2542

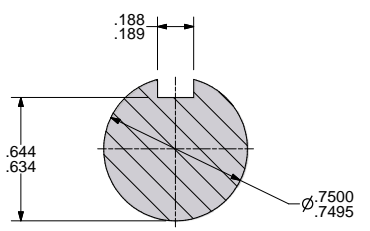
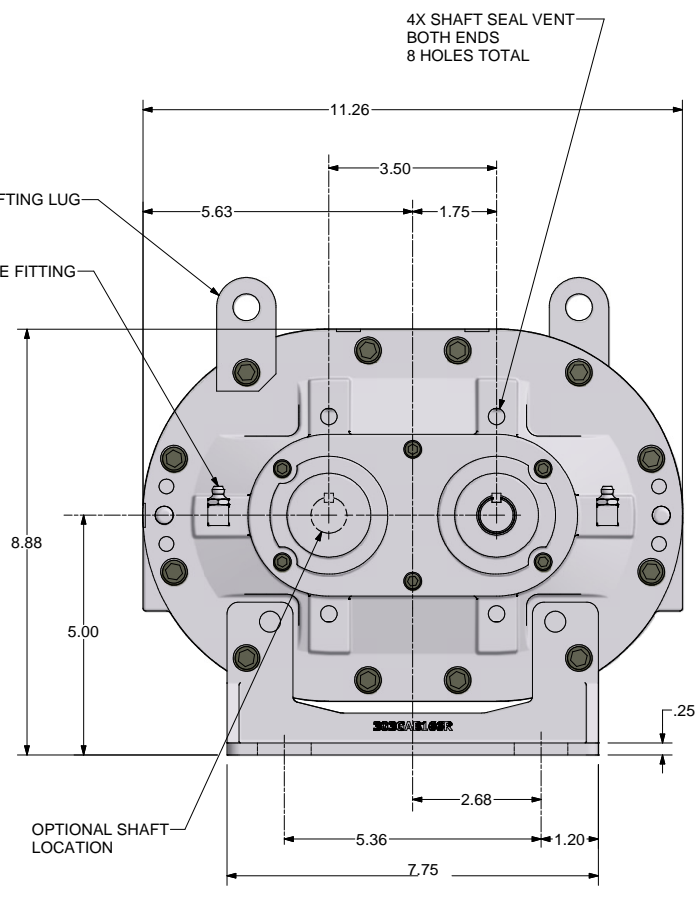
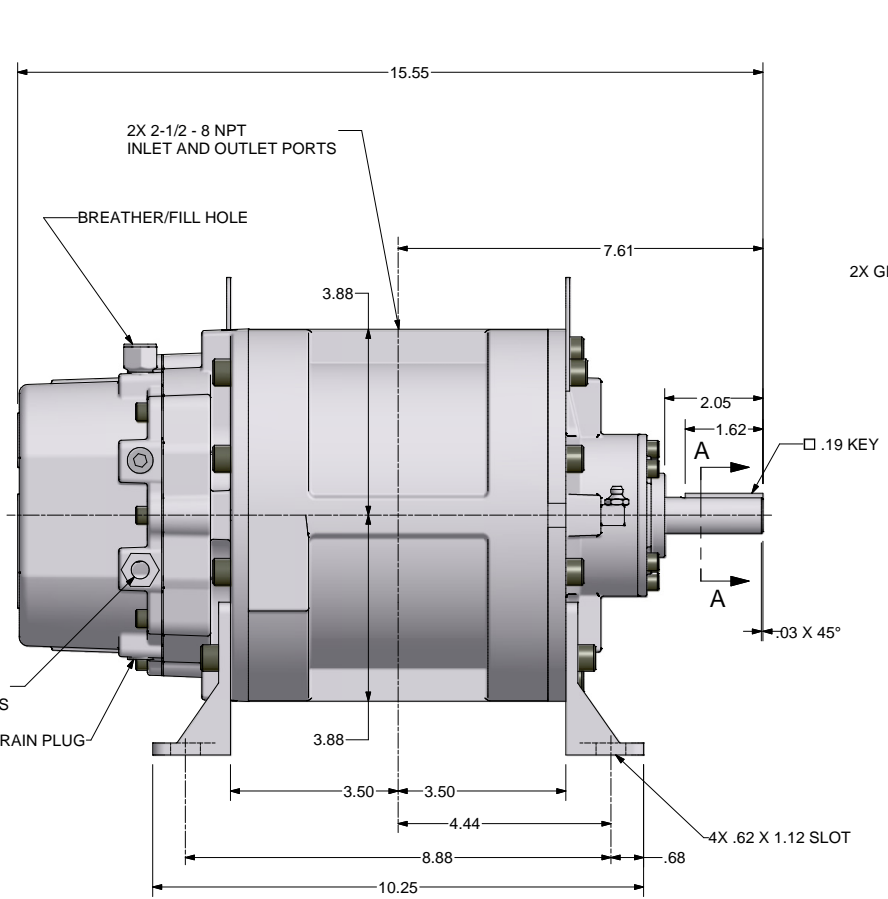

SECTION A-A  
SCALE 4 : 1

ALL ROTATIONS AND PORT LOCATIONS WHEN FACING SHAFT END

CONSTRUCTION	ROTATION	DISCHARGE PORT
HORIZONTAL RIGHT	CLOCK WISE (CW)	BOTTOM SIDE
	COUNTERCLOCKWISE (CCW)	TOP SIDE
HORIZONTAL LEFT	CLOCKWISE (CW)	TOP SIDE
	COUNTERCLOCKWISE (CCW)	BOTTOM SIDE

FINISH OF CHAMFERS AND FILLETS TO CONFORM TO ROUGHEN FINISH AREA. SURFACE ROUGHNESS MAXIMUM PER ASME B46.1. FULL THREAD DEPTH ARE MAXIMUM.

UNLESS OTHERWISE SPECIFIED DIMENSIONS ARE IN INCHES  
 TOL. ON DECIMALS: .X = ± .05  
 TOL. ON DECIMALS: .XX = ± .02  
 TOL. ON DECIMALS: .XXX = ± .01 AS SPECIFIED  
 TOL. ON ANGLES: ± 0.30

THIRD ANGLE PROJECTION

CONFIDENTIAL: THE INFORMATION CONTAINED IN THIS DOCUMENT IS THE PROPERTY OF GARDNER DENVER, INC. IT IS NOT FOR PUBLIC DISCLOSURE. POSSESSION OF THE INFORMATION DOES NOT CONVEY ANY RIGHT TO LOAN, REPRODUCE, OR DISCLOSE THE INFORMATION. UNAUTHORIZED REPRODUCTION OR USE OF THE INFORMATION IS PROHIBITED. THIS DOCUMENT IS TO BE RETURNED TO GARDNER DENVER, INC. UPON THE COMPLETION OF THE PURPOSE FOR WHICH IT IS LOANED OR UPON REQUEST.

DIMENSIONING AND TOLERANCING PER ASME Y14.5M-1994  
 THREADS PER ASME B1.1 (SAE SYSTEM) 21 UN UNF. ANSI B1.20.1 & B1.20.3

Gardner Denver Inc.	HEAT TREATMENT	ENG. REF. A
Quincy, IL	TITLE	OUTLINE-BARE UNIT
DWN BY: RNS 4/17/2009	3LR LEGEND GRS-SPL	
CD BY: RNS 4/17/2009	WSC	322GAB800
	FULL	