

REVISION HISTORY		DATE	DWN	CHK
ZONE	REV	DESCRIPTION		
	A	RELEASED PER ECN 1045640		

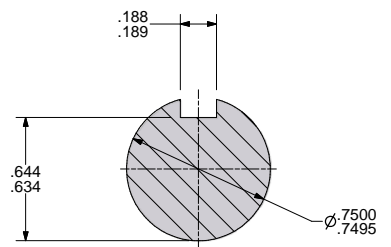
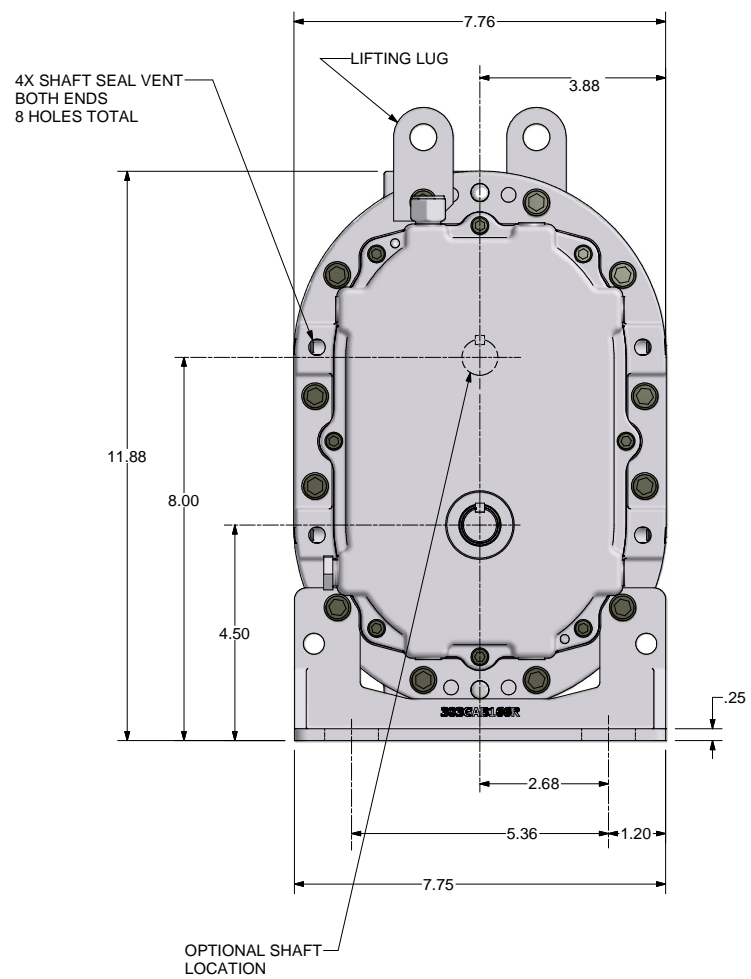
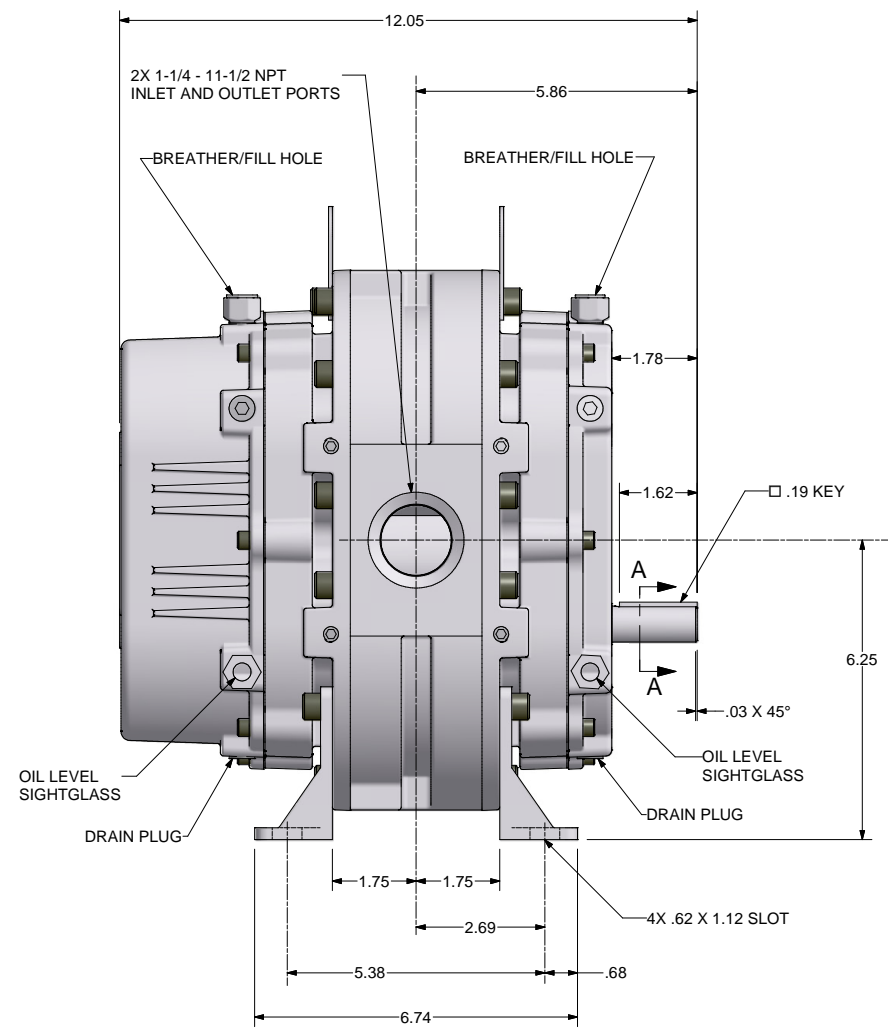

SECTION A-A  
SCALE 4 : 1

ALL ROTATIONS AND PORT LOCATIONS WHEN FACING SHAFT END

CONSTRUCTION	ROTATION	DISCHARGE PORT
VERTICAL BOTTOM	CLOCK WISE (CW)	LEFT SIDE
	COUNTERCLOCKWISE (CCW)	RIGHT SIDE
VERTICAL TOP	CLOCKWISE (CW)	RIGHT SIDE
	COUNTERCLOCKWISE (CCW)	LEFT SIDE

FINISH OF CHAMBERS AND FILLETS TO CONFORM TO DIMENSIONS SPECIFIED UNLESS OTHERWISE SPECIFIED DIMENSIONS ARE IN INCHES

TOL. ON DECIMALS: .X = ± .05  
TOL. ON DECIMALS: .XX = ± .02  
TOL. ON DECIMALS: .XXX = ± .01 AS SPECIFIED  
TOL. ON ANGLES: ± 0.30°

THIRD ANGLE PROJECTION

CONFIDENTIAL: THE INFORMATION CONTAINED IN THIS DOCUMENT IS THE PROPERTY OF GARDNER DENVER, INC. IT IS NOT FOR PUBLIC DISCLOSURE. POSSESSION OF THE INFORMATION DOES NOT CONVEY ANY RIGHT TO LOAN, REPRODUCE, OR DISCLOSE THE INFORMATION. UNAUTHORIZED REPRODUCTION OR USE OF THE INFORMATION IS PROHIBITED. THIS DOCUMENT IS TO BE RETURNED TO GARDNER DENVER, INC. UPON THE COMPLETION OF THE PURPOSE FOR WHICH IT IS LOANED OR UPON REQUEST.

DIMENSIONING AND TOLERANCING PER ASME Y14.5M-1994  
THREADS PER ASME B1.1; CHAMFER SYSTEM 21.1.0.1.1; ANSI B1.20.1 & B1.20.3

**Gardner Denver Inc.**  
Quincy, IL

DWN BY: RNS 4/17/2009  
C/D BY: RNS 4/17/2009

HEAT TREATMENT: ENG. REF. A

TITLE: OUTLINE-BARE UNIT

3HRV LEGEND DSL

WCS: 317GAB800

FULL

**C. Emery Nelson, Inc.**  
INDUSTRIAL AND POWER PLANT EQUIPMENT

7631 Commerce Street, Hamel, MN 55340  
Ph: 763/420-3844 Fax: 763/420-2542