



# C. Emery Nelson, Inc.

INDUSTRIAL AND POWER PLANT EQUIPMENT

7631 Commerce Street, Hamel, MN 55340  
 Ph: 763/420-3844 Fax: 763/420-2542

REVISION HISTORY				
ZONE	REV	DESCRIPTION	DATE	CHK
	A	RELEASED PER ECN 1045005		

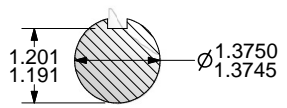
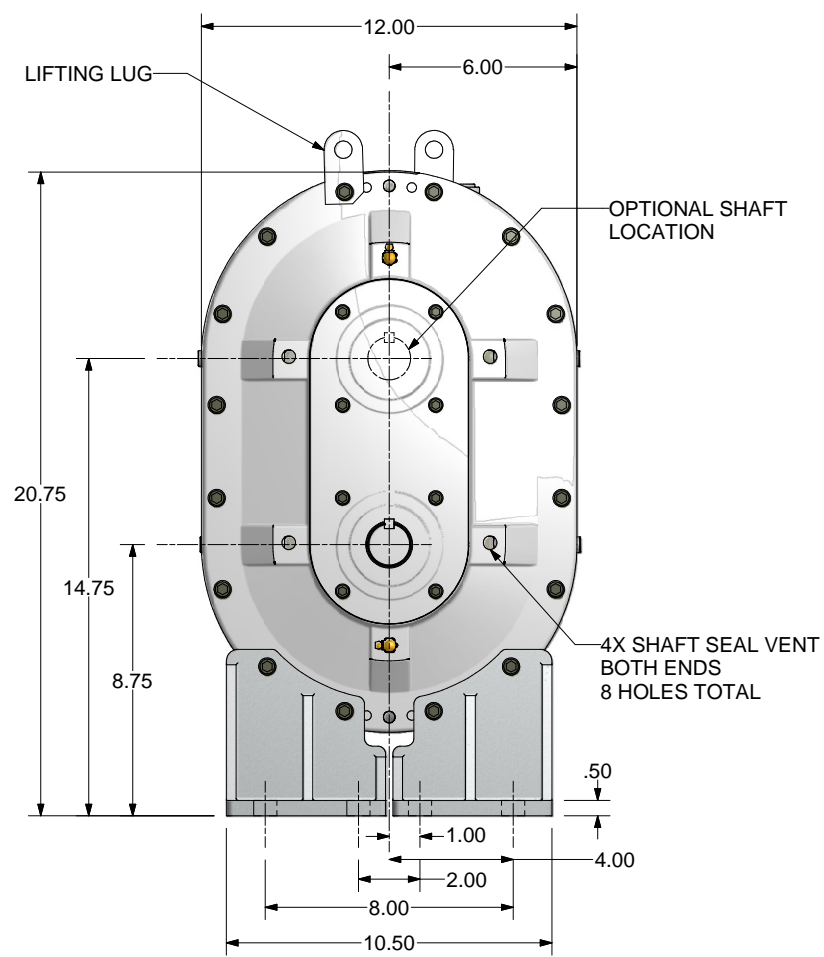
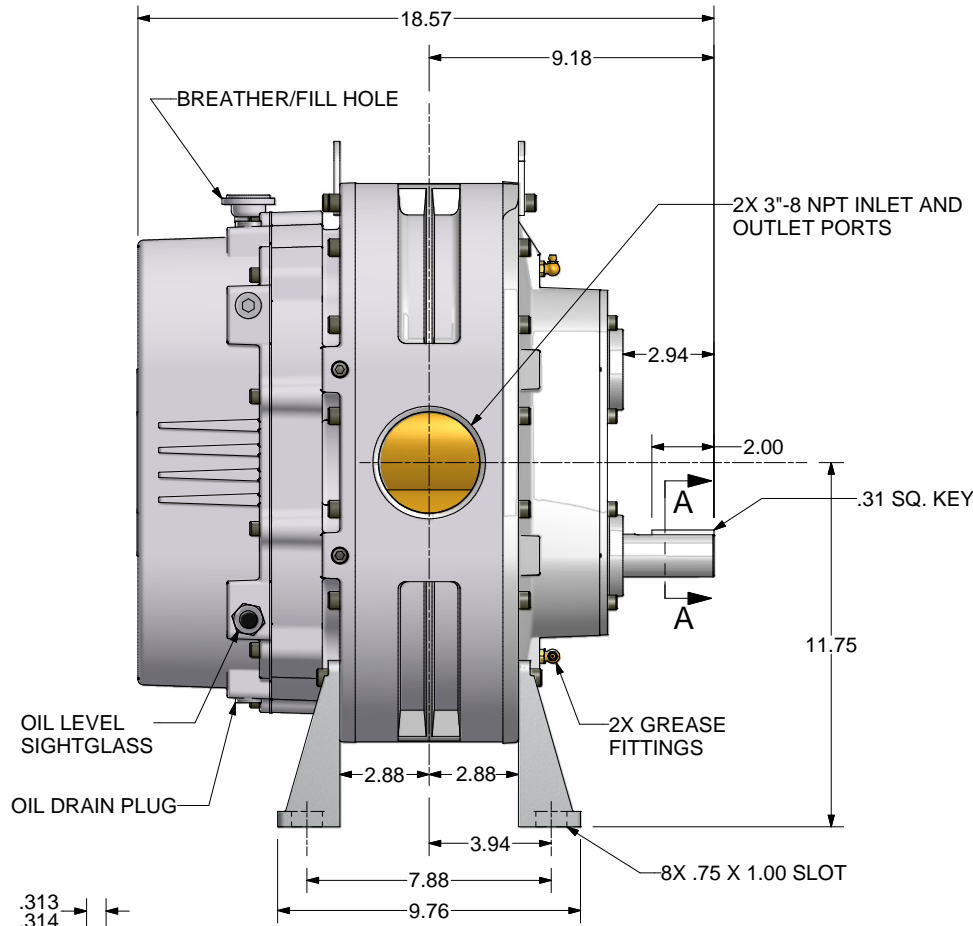

SECTION A-A  
 SCALE 1 : 1

ALL ROTATIONS AND PORT LOCATIONS WHEN FACING SHAFT END

CONSTRUCTION	ROTATION	DISCHARGE PORT
VERTICAL BOTTOM	CLOCKWISE (CW)	LEFT SIDE
	COUNTER CLOCKWISE (CCW)	RIGHT SIDE
VERTICAL TOP	CLOCKWISE (CW)	RIGHT SIDE
	COUNTER CLOCKWISE (CCW)	LEFT SIDE

FINISH OF CHAMFERS AND FILLETS TO CONFORM TO ROUghest ADJACENT AREA.  
 SURFACE ROUGHNESS MAXIMUM PER ASME B46.1.  
 FULL THREAD DEPTHS ARE MINIMUM.

UNLESS OTHERWISE SPECIFIED  
 DIMENSIONS ARE IN INCHES

TOL. ON DECIMALS: X = ± .05  
 TOL. ON DECIMALS: XX = ± .02  
 TOL. ON DECIMALS: XXX = ± AS SPECIFIED  
 TOL. ON ANGLES: ± 0'-30'

THIRD ANGLE PROJECTION

CONFIDENTIAL - THE INFORMATION CONTAINED IN THIS DOCUMENT IS THE PROPERTY OF GARDNER DENVER, INC. IT IS NOT FOR PUBLIC DISCLOSURE. POSSESSION OF THE INFORMATION DOES NOT CONVEY ANY RIGHT TO LOAN, SELL OR DISCLOSE THE INFORMATION. UNAUTHORIZED REPRODUCTION OR USE OF THE INFORMATION IS PROHIBITED. THIS DOCUMENT IS TO BE RETURNED TO GARDNER DENVER, INC. UPON THE COMPLETION OF THE PURPOSE FOR WHICH IT IS LOANED OR UPON REQUEST.

DIMENSIONING AND TOLERANCING PER ASME Y14.5M-1994  
 THREADS PER ASME B1.1 GAGING SYSTEM 21 U.O.S., ANSI B1.20.1 & B1.20.3

<b>Gardner Denver</b>		HEAT TREATMENT	ENG. REF:
Gardner Denver Inc. Quincy, IL		TITLE: <b>OUTLINE-BARE UNIT</b>	
DWN BY TAM 3/11/2009		SIZE: 6HVR GRS-SPL	311GAF800
CKD BY RNS 3/11/2009	SCALE: 1/2	SHEET 1 OF 1	