

REVISION HISTORY		DATE	DWN	CHK
ZONE	REV	DESCRIPTION		
	A	RELEASED PER ECN 1045640		

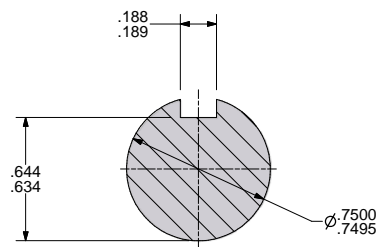
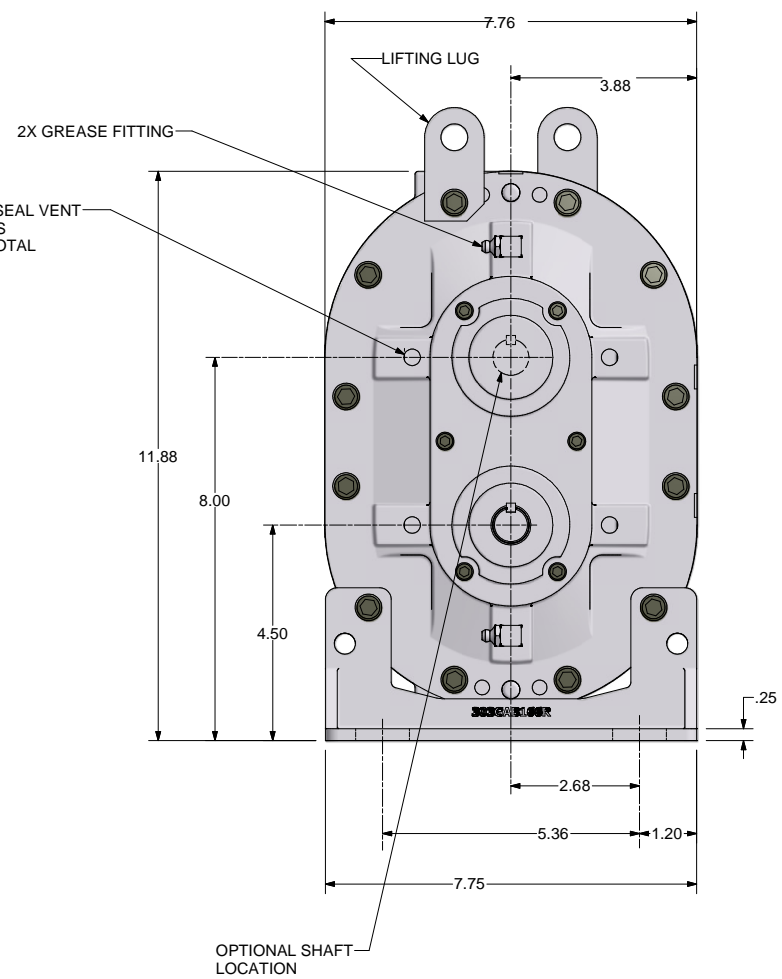
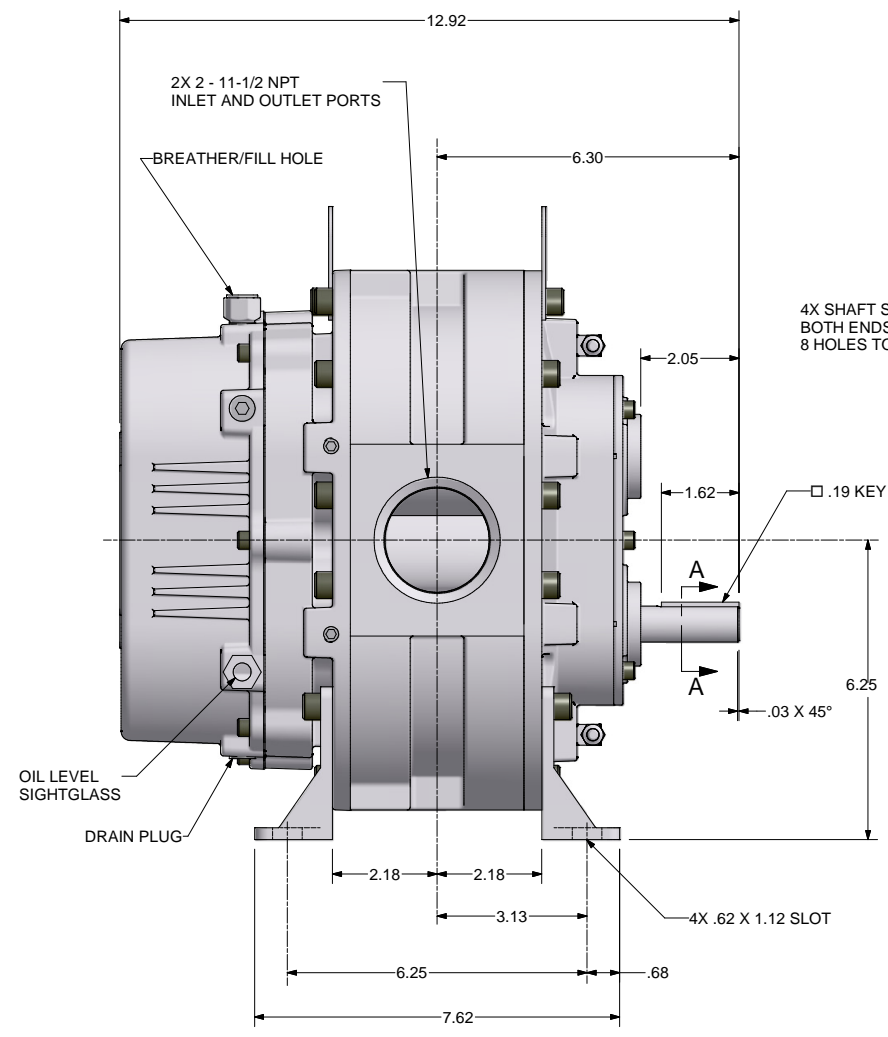

SECTION A-A
SCALE 4 : 1

ALL ROTATIONS AND PORT LOCATIONS WHEN FACING SHAFT END

CONSTRUCTION	ROTATION	DISCHARGE PORT
VERTICAL BOTTOM	CLOCK WISE (CW)	LEFT SIDE
	COUNTERCLOCKWISE (CCW)	RIGHT SIDE
VERTICAL TOP	CLOCKWISE (CW)	RIGHT SIDE
	COUNTERCLOCKWISE (CCW)	LEFT SIDE



C. Emery Nelson, Inc.
INDUSTRIAL AND POWER PLANT EQUIPMENT

7631 Commerce Street, Hamel, MN 55340
Ph: 763/420-3844 Fax: 763/420-2542

FINISH OF CHAMFERS AND FILLETS TO CONFORM TO DIMENSIONS SPECIFIED UNLESS OTHERWISE SPECIFIED DIMENSIONS ARE IN INCHES
TOL. ON DECIMALS: .X = ± .05
TOL. ON DECIMALS: .XX = ± .002
TOL. ON DECIMALS: .XXX = ± .001
TOL. ON ANGLES: ± 0.30

CONFIDENTIAL: THE INFORMATION CONTAINED IN THIS DOCUMENT IS THE PROPERTY OF GARDNER DENVER, INC. IT IS NOT FOR PUBLIC DISCLOSURE. POSSESSION OF THE INFORMATION DOES NOT CONVEY ANY RIGHT TO LOAN, REPRODUCE, OR DISCLOSE THE INFORMATION. UNAUTHORIZED REPRODUCTION OR USE OF THE INFORMATION IS PROHIBITED. THIS DOCUMENT IS TO BE RETURNED TO GARDNER DENVER, INC. UPON THE COMPLETION OF THE PURPOSE FOR WHICH IT IS LOANED OR UPON REQUEST.

THIRD ANGLE PROJECTION

DATE: 4/17/2009
DWN BY: RNS
C/D BY: RNS

DATE: 4/17/2009
E: WSC
FULL

HEAT TREATMENT: 3MVR LEGEND GRS-SPL
ENG. REF: A

TITLE: OUTLINE-BARE UNIT

324GAB800